

Analysis of Various Automotive Mufflers: Computational Fluid Dynamics Approach

C. Mohan Raj¹; S. Padmavathy²; M. Gokulnath³; M. Saran Kumar⁴; L. Pragadheesh⁵

¹Department of Mechanical Engineering, M. Kumarasamy College of Engineering, Karur, Tamil Nadu, India.

¹mohan.aero@gmail.com

²Department of Mechanical Engineering, M. Kumarasamy College of Engineering, Karur, Tamil Nadu, India.

²padmavathy.sk@gmail.com

³Department of Mechanical Engineering, M. Kumarasamy College of Engineering, Karur, Tamil Nadu, India.

³gokul.n.54107@gmail.com

⁴Department of Mechanical Engineering, M. Kumarasamy College of Engineering, Karur, Tamil Nadu, India.

⁴sarankumar2502@gmail.com

⁵Department of Mechanical Engineering, M. Kumarasamy College of Engineering, Karur, Tamil Nadu, India.

⁵lpragadheesh@gmail.com

Abstract

Muffler contributes extensively to decrease the backpressure and the noise pollution. It is essential to compare and display the overall performance of muffler system. This paper offers the results of the performance of an actual and modified automotive muffler system. The results of the automotive mufflers performance analysis are presented and a comparison is made to the decrease of backpressure and to increase the efficiency. Muffler modelling are performed in SolidWorks software and simulation analysis performed in ANSYS CFD (Fluid Flow) tool. The main purpose of this project is to optimize the automotive muffler through changing its internal designs to decrease the backpressure. Three designs are made with same dimensions and different internal designs are analysed in ANSYS CFD tool. Finally, the results are discussed in detail and the performance of the automotive muffler is showed in different variations.

Key-word: Muffler, Back Pressure, Solid Works, ANSYS CFD, Mesh.

1. Introduction

Muffler is one of the important parts and it is situated in exhaust system of the car. It is essential for the exhaust system of vehicle's engine to reduce the noise emission and back pressure. The muffler is engineered as an acoustic sound proofing device designed to reduce the noise emission

as well as back pressure that improves the performance of the engine. Backpressure is directly related with the engine performance. Increase in backpressure reduces engine net power, increase the torque and this can be lead to increase fuel consumption CO emissions and exhaust temperature. Decrease in back pressure results in increasing in engine efficiency as well as the engine gives maximum output. Muffler are mainly divided into three types are reactive muffler, absorptive muffler and hybrid muffler. Hybrid muffler is the combination of the reactive and absorptive muffler. The literature reviews had considered for this project listed below.

The design of a muffler chamber, restrictions on the flow of exhaust gases, and the material of the muffler are all the important factors that affect the muffler's performance. The backpressure is inversely proportional to the noise of the muffler; decreasing the noise level will result in increasing of backpressure. Thus, muffler with low backpressure will have high efficiency[1]. Solid Works is used to design and analyse the muffler. The muffler was designed with proper measurements. Dynamic analysis was used to evaluate the shapes, stresses and deformations in muffler. In comparison to a single expansion chamber, a double expansion chamber produces better performance[2]. This analysis paper explained the work done by various authors. Several methodologies that had been used while constructing an exhaust muffler. According to the findings, there is a large market for open flow or straight through mufflers that are more powerful in terms of reduced pressure drop and better fuel efficiency[3]. A muffler was created to meet the requirements of sufficient insertion failure, minimal backpressure, space constraints and the reliability while also producing the least number of noise. Therefore, a well-designed muffler can provide the best noise reduction[4].

A vehicle muffler should be manufactured to meet the functional specifications, including sufficient insertion loss, space constraints, minimal back pressure, durability, sound production and cost effectiveness. There are different muffler design solutions for different situations but the design is proved by the performance[5]. The muffler's thermal analysis has been evaluated. The results of the simulated muffler models are extremely useful. In this experiment also explained that the heat flux would be minimum at the muffler's initial point and maximum at the opening[6]. Different designs were developed and simulated in software in comparison to the current muffler of the car. Based on the simulation design 1 and design 6 are performed much better in terms of pressure loss. However, merit and demerit are often related and increase in pressure loss would result in increase in back pressure, which is bad for the engine[7].

In this project a CFD simulation of an existing muffler was used to calculate the existing pressure drop, temperature and wall heat transfer coefficient. According to the contour, replacing the

original muffler with a perforation of diameter resulted in a pressure drop[8]. The results of the experiment showed that the changed design reduces backpressure as compared to the initial design. The reduction in back pressure would almost certainly result in improved efficiency and longer engine life while consuming less fuel[9]. The aim of this experiment was to perform a design and free study of a muffler device in order to evaluate the system's resonant frequencies and make design suggestions. The resonance frequencies were calculated by Nastran software, which was then compiled to determine the peaks were the most important for the device. Side baffles were classified as weak sections of the muffler based on the results. The suggested design change to mitigate the effects of these resonance frequencies to add thickness and damping to the device[10].

The main Objective of this project is to reduce the backpressure in order to increase the performance of the engine. CFD simulation analyses are done to validate the parameters such as Pressure, Velocity, Temperature and Turbulence. The work done (Methodology) for this project are started from the literature survey which is mentioned above, by this the problem was found then we perform a design works in SolidWorks with the reference of a car muffler, then we perform a simulation analysis in ANSYS CFD tool to validate the parameters and then the results are concluded.

2. Materials and Methods

The materials that will be used for this project as follows SolidWorks (CAD) and ANSYS (CFD). The modelling and analysing methods are described further down. The use of software to assist in the development, modification, analysis or optimization of a model is known as computer-aided design (CAD). CAD software is used to improve the designer's efficiency, the quality of design, documentation and development of database for manufacturing. SolidWorks CAD software is a mechanical design automation programme that enables designers to quickly map out designs, experiment with features and dimensions and built models and detailed drawings. A SolidWorks model is made up of 3D geometry that allowing you to build models quickly and accurately.

The virtual design of the automotive muffler must provide a precise estimation of the space needed for the exhaust, backpressure to the engine, device weight, gas species distributions and a gas temperature distribution at a minimum. For a better performance, the Maruti-Suzuki WagnR muffler is being used as a reference muffler to compare with proposed muffler configurations with the same or engine exhaust parameters.

Table 1 - Maruti- Suzuki WagnR Muffler Data

Symbol	Parameter	Dimensions
L	Length	350 mm
W	Width	235 mm
H	Height	135 mm
OD	Inlet pipe Diameter	40 mm
ID	Inlet pipe Diameter	38 mm
OD 1	Outlet pipe Diameter	35 mm
ID 1	Outlet pipe Diameter	33 mm
d	Diameter of Holes	8 mm
N	Number of Perforated holes	45

A model 1 is created in SolidWorks and simulated in ANSYS CFD using the above-mentioned muffler data. Figure 1 depicts the view of the muffler model 1. It has three chambers an inlet, an outlet chamber, a centre as well as perforation tubes and baffles. A model 2 has wide internal flow tubes that increase exhaust flow while lowering backpressure. On most applications, this exclusive flow director architecture channels exhaust flow and prevents turbulence. This technology is also intended to minimise unnecessary interior resonance while retaining a friendly performance tone. A figure 2 shows the view of model 2. A model 3 is designed with a V-shaped structure that separates the exhaust gas by sliding their surfaces. As a result, the backpressure of the exhaust gas is significantly reduced and this design often incorporates excellent sound cancellation. A figure 3 shows the view of model 3.

Fig. 1 - SolidWorks View of Model 1

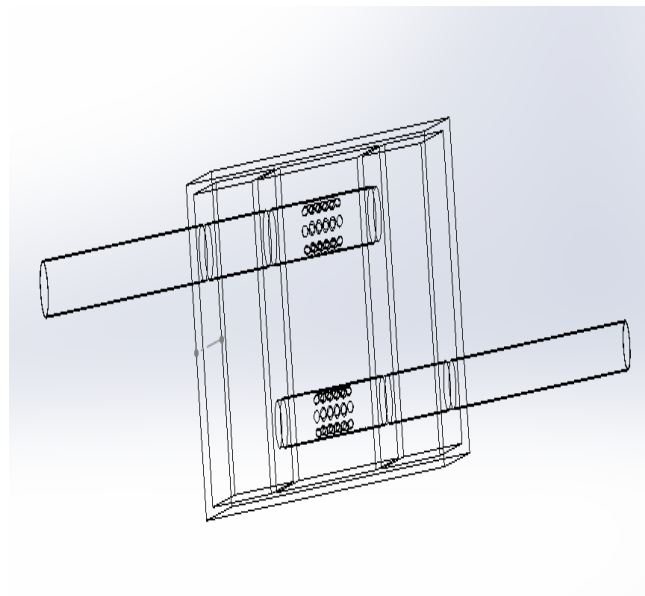

Fig. 2 - SolidWorks View of Model 2

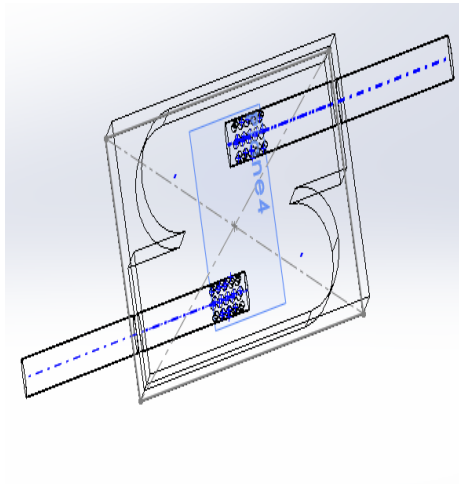
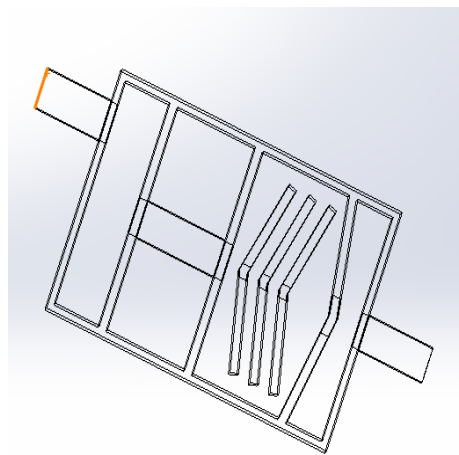

Fig. 3 - SolidWorks View of Model 3



A computational approach for solving engineering and mathematical physics problems is known as **finite element method (FEM)**. In order to solve the problem, it divides a broad problem into smaller sections, which are referred to as finite elements. Finite element analysis is a term used to describe the method of researching or analysing a phenomenon using FEM (FEA). **Computational fluid dynamics (CFD)** is a branch of fluid mechanics that analyses and solves problems involving fluid flows using numerical analysis and data structures. CFD is seen as a bridge between pure experimentation fluid dynamics and natural theoretical fluid dynamics. By the CFD analysis, the complex engineering problems has been reduced significantly. In the CFD analysis, the Geometry is created in the ANSYS Design Modular or that has been created in a CAD system. **ANSYS meshing** is used to find solutions for real flows, a numerical approach must be used, in which the equations are replaced by algebraic approximations that can be solved using a numerical procedure. The governing

equations are discretized by fragmenting the spatial domain into small finite control volumes with the aid of mesh.

Fig. 4 - Meshed geometry of Muffler

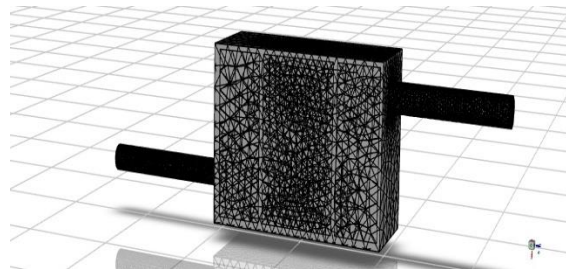

Fig. 5 - Meshed Geometry of Muffler

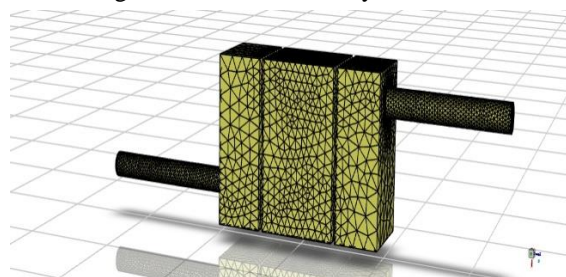

Table 2 - Boundary Conditions for CFD Analysis

Inlet Conditions	
Inlet velocity	40 m/s
Inlet Temperature	773 k
Density(Constant at temperature)	1.225 kg
Outlet Conditions	
Opening at outlet	0.05 Pa
Outlet Temperature	300 k
Energy	On

For this boundary condition, the analysis was carried out using ANSYS CFD tool. Each muffler is examined using the same boundary conditions as those described previously.

3. Results and Discussion

Muffler analysis was performed using the ANSYS CFD tool on severally designed mufflers. The simulation analysis results are calculated for validation purposes and the outcomes of the various designs are discussed. The design 1 shows the existing model of the Maruti-Suzuki WagonR car. The design 2 and design 3 are with the same dimensions of the existing muffler. The dimensions of the

inlet and outlet pipe are kept same and the interior designs are changed and analysed in the ANSYS CFD.

Fig 6. Pressure Contour of Muffler

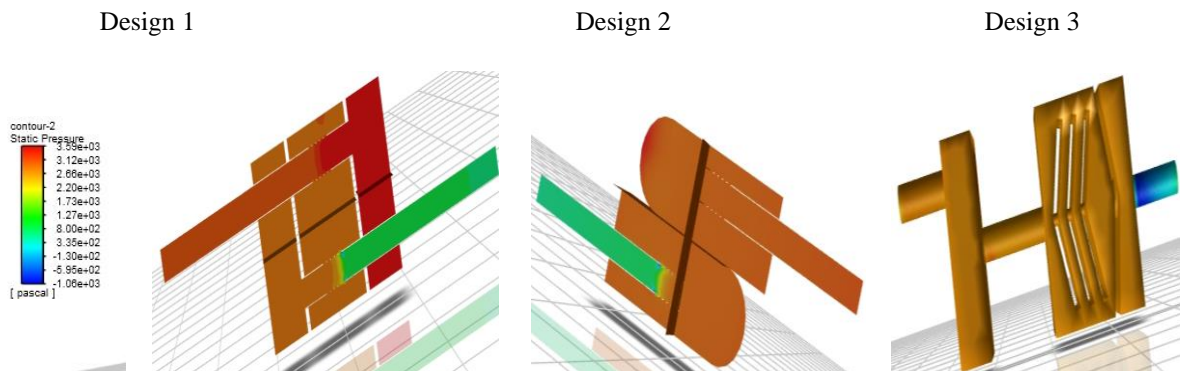

From the pressure contour in [figure 6] we can find the maximum pressure in the inlet chamber of the muffler and gradually decrease in the other chamber. In the mufflers, the maximum pressure is 3590 Pa and the minimum pressure is 1060 Pa. In the above figure, the outlet pipe shows the better and minimum pressure drop. When compared with the previous papers, the pressure loss is about 6105Pa but in this research the pressure loss is about 3590Pa so the pressure loss is gradually decreased. In the pressure contour figures show that design 3 has a minimum pressure drop when compared with the other designs.

Fig. 7 - Velocity Contour of Muffler

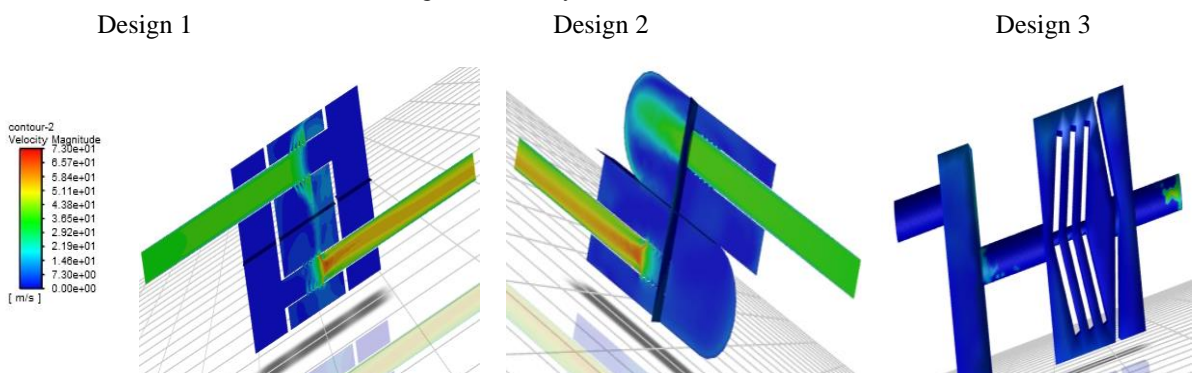

The pressure is inversely proportional to the velocity. The velocity contour [figure 7] shows that the minimum velocity in the inlet pipe and uniformly in other chambers then maximum in the outlet pipe. The maximum velocity value is 73 m/s and the minimum velocity value is 0 m/s. Due to the pressure drop, the velocity at the outlet pipe is much higher. The velocity in the design 1 and design 2 shows that ununiformed flow or the uneven distribution over the chambers. The design 3

shows the uniform flow of fluid almost all over the chambers. When comparing all the designs, the design 3 is better. This uniform flow will reduce the turbulence, which is good for the muffler.

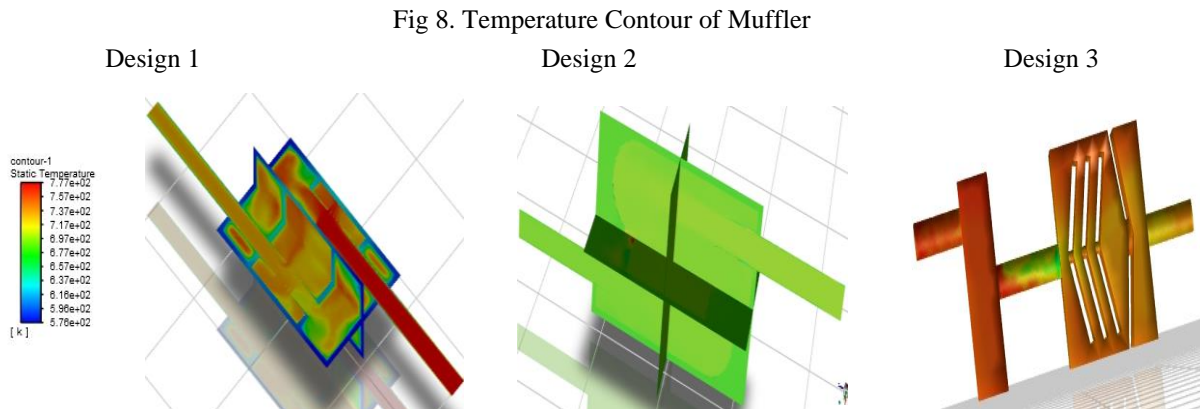

The temperature contour [figure 8] shows the temperature distribution all over the chambers. The temperature distribution varies in all the designs. In design 1 and design 3, the temperature varies from maximum to minimum in all the chambers. In the design 2, the temperature is moderate throughout all the chambers. The temperature varies according to the engine parameters. The value of the minimum temperature is 578K and the maximum temperature is 777K.

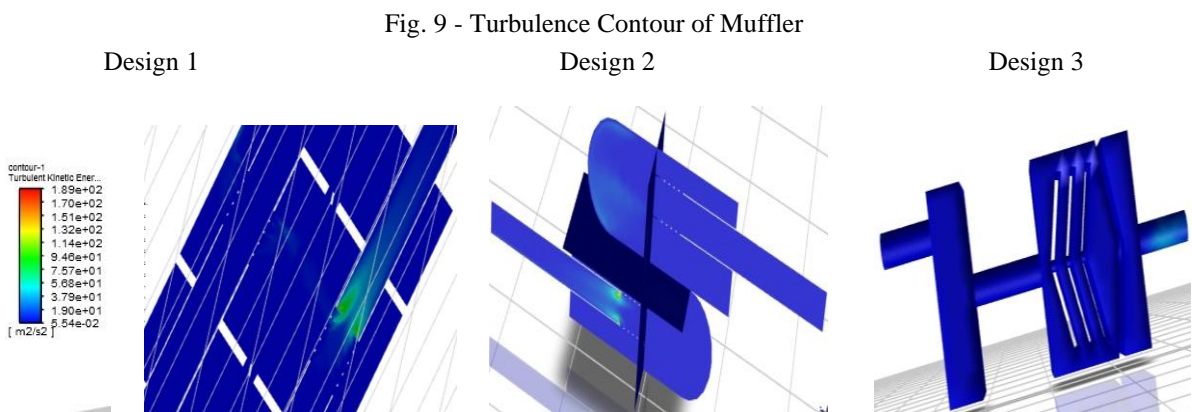

The turbulence contour [figure 9] shows the distribution of fluid all over the chamber. In design 1 and design 2 show that moderate turbulence formed in the outlet chamber of the muffler. In the design 3 shows that the fluid flows uniformly (laminar flow) inside the pathway. The maximum turbulence value is 189 m²/s² and the minimum turbulence value is 0.05 m²/s². When comparing the designs, the design 3 is better. It will distribute the pressure equality all over the chamber and also increase the performance of the muffler.

Fig. 10 - Pressure Drop across the model

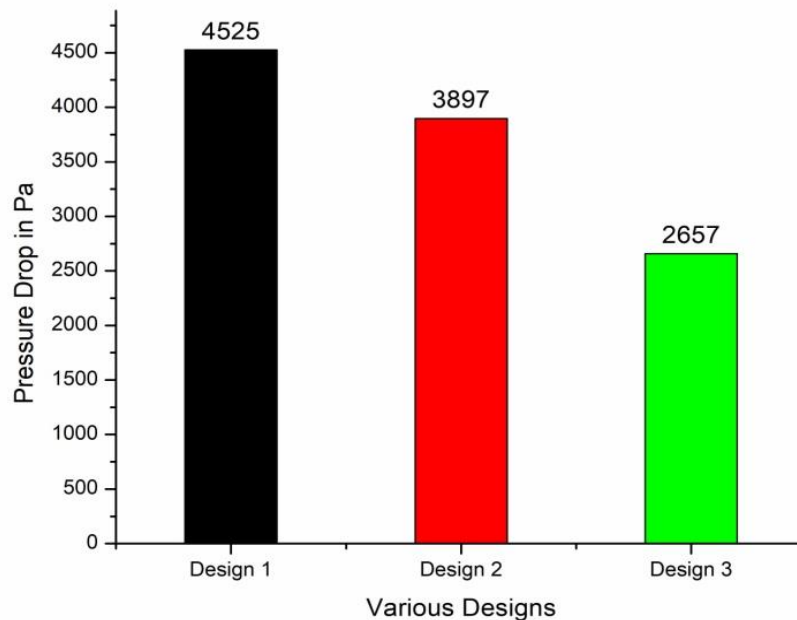

[Figure 10] shows that the pressure drop occurred in various designs of mufflers. From the graph, it is found that design 1 has a maximum pressure drop of 4525Pa, design 2 has a pressure drop of 3897Pa and design 3 has a minimum pressure drop of 2657Pa. minimum pressure drop will decrease the back pressure. When compared with the previous papers (6137Pa-4325Pa) and other designs, the design 3 with the minimum pressure drop (2657Pa) is better. So, the design 3 is best for using as a muffler in a vehicle where minimum back pressure is required. From this graph, we obtained that the pressure drop will lead to increased performance.

4. Conclusion

Various mufflers are compared and then the comparison between the CFD analysis of various mufflers are noted. The work concluded CFD analysis will be done to determine the Backpressure along with the parameters analysed such as Pressure, Velocity, Temperature and Turbulence. A paper described the CFD Analysis of Automotive muffler from modelling to analysis and all works carry on SolidWorks and ANSYS FLUENT.

From the simulation results analysed it is concluded that Design 3 is better in pressure drop so with the maximum pressure drop the back pressure also decreases. The decrease in back pressure from 4525Pa to 2657Pa results good in performance of the engine. So We can prefer a design 3 among the designs analysed.

References

- Rajasekhar Reddy M, Madhava Reddy K. (2012). *Design and optimization of Exhaust Muffler in Automobiles*. Vol. 2 ISSN 2277- 4785.
- Praveen R, Kalyana Kumar Mohamed S, Rafi, Mufash Ali, Raj Bharath. (2018). *Design and analysis of automobile Muffler*. Volume 118 No. 5, 1053-1060
- Potente and Daniel. (2005). *General design principles for an automobile Muffler*. www.daydesign.com.au
- Vaibhav D Prajapati, Ankit J Desai. (2016). *Design and analysis of automotive muffler*. Vol 5 ISSN 2278-0181
- Gnanendhar Reddy and Prakash N. (2016). Design and fabrication of Reactive Muffler. ISSN 0972-768X
- Mohiuddin A.K.M, Mohd Rashidin Ideres, Shukri Mohd Hashim. (2005). *Experimental study of noise and backpressure for silencer design Characteristics*. ISSN 1812- 5654
- Nilesh Kurangal and Dr Sangarampatil. (2020). *Experimental testing and CFD Simulation of Existing Muffler*. Volume 07 ISSN 2395- 0056
- Christopher George T and Vinod Raj HG. (2018). Energy efficient design and modification of an automotive exhaust muffler for optimum noise, transmission loss, insertion loss and backpressure: a review. *Sci. Eng.* 377 012127
- Mohd Umair, Abdul Basit, Arun Prabhakar, Anshul Gautam. (2018). *Modification in muffler design to reduce the backpressure*. Vol 5, ISSN 2319- 8753
- Venkata Ramesh Mamilla, Sowdagar Moin Ahmed, Lakshmi Narayana Rao. (2016). *Design and analysis of an automobile exhaust muffler*. Vol 1 No 1 pp 10-15.