

Application of CAD/CAM in the Design of Machining Process and Tooling Devices for Flange Tube

Musa Alhaji Ibrahim^{a*}, Huang Kai^b & Mustapha Mukhtar Usman^c

^aDepartment of Mechanical Engineering,
Faculty of Engineering, Kano University of Science and Technology, Wudil, Kano State, Nigeria

^bDepartment of Mechanical Engineering and Automation,
Liaoning University of Technology, Jinzhou, Liaoning Province, China

^cDepartment of Mechanical Engineering Technology,
School of Technology,
Kano Polytechnic, Kano State, Nigeria

*Corresponding author: abbanfati2014@gmail.com

Received 19 February 2019, Received in revised form 13 May 2019

Accepted 23 September 2019, Available online 28 February 2019

ABSTRACT

Recently, computer-aided design and computer aided manufacturing (CAD/CAM) is largely applied in universal machinery due to the accelerated development of computer technologies. Owing to the technical application of CAD/CAM tool in the manufacturing industry, enterprises have progressively changed their traditional approaches to design and manufacture of products. The CAD module provides product designers with capabilities of designing product model by feature-based design and obtaining product data. The product model is displayed on a screen in the CAD environment before transferring it downstream to the CAM module. This paper presents the application of CAD/CAM in solid modelling, design of machining process, fixture design and virtual manufacture of a flanged tube. Pro/Engineer (Pro/E) Wildfire 4.0 was used to create the three dimensional (3D) model of the flange tube based on its two-dimensional drawing (2D) blank drawing and the mould was designed and created using the same software. The mould creation was based on the clamping and positioning devices of the flange tube being manufactured. The technical schedule of the flange tube was worked out including the choice of machining method, machine tool, cutting tool and selection and computation of machining parameters based on finished drawing the flange tube. Two dedicated fixtures for holding the flange tube in the machine tool were designed and finally Master CAM 9.0 software was applied to the virtual machining of the mould. It is concluded that CAD/CAM tool is important in manufacturing technology as it automates the manufacturing process thereby saving time, energy, cost, and making production highly flexible.

Keywords: CAD/CAM; Machining process; Pro/Engineer; Fixture; Tooling devices

INTRODUCTION

Computer-aided design/Computer-aided manufacturing (CAD/CAM) technology has achieved a breakthrough in the technical application of computer technologies for manufacturing products thus leading to efficiency, high quality and minimum cost of production (Naumov & Pandilov 2015). Manufacturing industries have witnessed monumental changes due to CAD/CAM tools in product design and fabrication (Chwastyk & Kolosowk 2012). CAD/CAM tools such as Pro/Engineer (Pro/E) and Master CAM are being implemented in the manufacturing industries thus providing efficiency, control and computerized management systems (Anna et al. 2009) in the production function. CAD refers to the use of computer technology for the design of objects, real or virtual (Ravi 2008). It is usually associated with interactive computer graphics, known as CAD systems. These systems are powerful tools and are used in the

design and manufacture of components (Farin et al. 2002). However, CAD frequently involves more than just shapes, as in the manual drafting of technical and engineering drawings, the output of CAD often must convey symbolic information such as materials, processes, dimensions and tolerances, according to application-specific conventions (Mattson 2009). On the other hand, CAM involves the use of computer-based software tools that assist engineers and machinists in manufacturing or prototyping product components (Farin 2002). CAM assists in all operations of a manufacturing plant, including machining process planning (Ginting & Haron 2005); management, transportation and storage, its primary purpose is to create a faster production process and components with more precise dimensions (Radhaakrishnan et al. 2008; Kong & Song 2013; Narayan et al. 2008). Integration of CAD and CAM plays an increasingly important role in modern manufacturing systems and as such, the technology has rapidly developed and widely spread in

manufacturing industries (Kalpakjian et al. 2010). Usman et al. (2016) used CAD/CAM tool to fabricate a component. Pro/E was applied to model the 3D of the part and UNIGRAPHICS was used for the virtual production of the part. They observed that the tools are powerful in virtually producing the component using real material. Liao et al. (2011) applied CAD/CAE tool for optimization of riser design technology. CAD/CAE tool simulated the heat transfer and then separated the liquid phases of the steel with no risers. The separated liquid phases were displayed on Unigraphics and the risers automatically developed. Then a simple casting test was employed to evaluate the CAD/CAE system. The results indicated suitable design of risers and it was concluded that the CAD/CAE reduced the time for riser design in casting process thereby ensuring casting quality and saving cost and energy. Sulaiman et al. (2018) while applying CAD/CAE tool to design and investigate plastic injection mold reported that the tool could predict the defects of the mold at cheaper rate thus reducing production time and ensuring fabrication of quality product.

Tolerance is the acceptable range for a physical dimension, which is determined by the product design based on form, fit and function of a part in the assembly (Kassim et al. 2018). Tolerances are important in the manufacturing process because they will determine how well a part will fit in the final piece and how reliable the final product will be (Krogstie et al. 2015; Hunter et al 2006). Tolerance is expressed as lower (-) and upper (+) limits of measurement in manufacturing. Fittings for a part that is welded have their own tolerance, whereas parts that are machined by a CNC machine, for instance, will not have the same tolerances, due to the fittings are not important with a bent part. Proper allocation of tolerances in a component of mechanical systems minimizes cost thereby assuring interchangeability of parts (Bruce 1987) and the parts when assembled are within their specifications (Nadeem 2011).

The fixture is a special tool for holding, locating, clamping and supporting a workpiece during assembly, machining or inspection (Shailesh & Laukik 2014). Frequent checking, positioning, individual marking and non-uniform quality in manufacturing process is eliminated by fixture. This increases productivity and reduces operation time. Fixture is widely used in the production industry because of its features and advantages (Pachbhai & Raut 2014). To maintain the static equilibrium of the fixture, the forces acting on the fixture should be analyzed (Hargrove 1995). A fixture consists of a set of locators and clamps. Locators are used to determine the position and orientation of a workpiece, whereas clamps exert clamping forces so that the workpiece is pressed firmly against locators. Clamping has to be appropriately planned at the stage of machining fixture design (Mervyn et al. 2006). The design of a fixture is a highly intricate and intuitive process, which requires knowledge. Fixture design plays an important role at the setting up planning phase. Proper

fixture design is crucial for developing product quality in different terms of accuracy, surface finish and precision of the machined parts (Pachbhai & Raut 2014). Supporting elements such as base plate and angle bracket are used in the fixture design and assembly. Locating elements like v-blocks, supporting plates, pins as well as bars, clamps and bars as clamping elements should be considered in fixture design (Peshatwar and Raut, 2014). In this study, a flange tube machining design process and tooling devices will be carried out using CAD/CAM tools.

METHODOLOGY

MATERIAL

The material used is Stainless Steel Grade 174 (UNS S17400) which is the most widely used steel of the precipitation hardening grade steels. It has high toughness, strength, and corrosion resistance. The chemical composition of the material is as shown in table 1.

3D MODELLING OF THE FLANGE TUBE

Pro Engineer (Pro/E) Wildfire 4.0 features were repeatedly exploited in modelling the flange tube. The Pro/E software based features were used in creating the important geometrical structure of the part. These features were made up of primitive shapes viz.: bend (elbow-like shape) and circular shapes and ellipse that give the part its major geometry and followed by modifiers that facilitated the creations of engineering features such as corners, rounds, chamfers, other cavities and contour radii of the part. The design variables for the part are circles radii of 194.66 mm, 42.58 mm and for the two ellipse Rx1 = 49.44 mm, Ry1 = 59.665 mm and Rx2 = 98.22 mm and Ry2 = 113.50 mm and nine holes of radii 18.00 mm and depth 7.40 mm and round dimension of 7.29 mm. Figure 1, Figure 2 and Figure 3 show the as-cast blank and 3D model of top and front and left views of the flange tube, respectively.

TABLE 1. Showing the composition of the material

Element	Composition (%)
Fe	73
Cr	15.0-17.5
Ni	3.0-5.0
Cu	3.0-5.0
Mn	1.0
Si	1.0
Ta	0.45
Nb	0.45
Nb + Ta	0.15-0.45
C	0.070
P	0.040
S	0.030

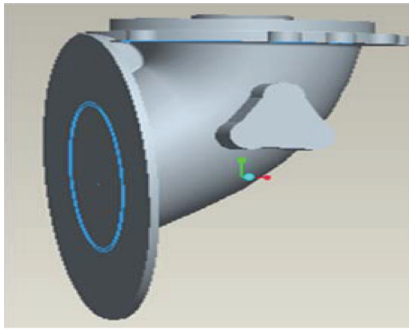

FIGURE 1. As-cast blank

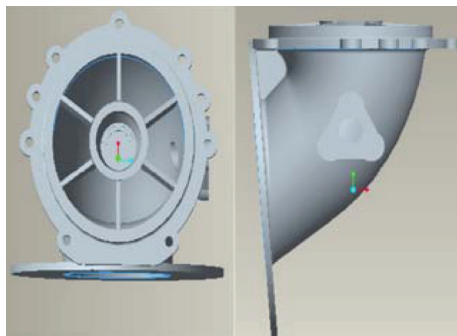

FIGURE 2. 3D top and front views of the flange tube

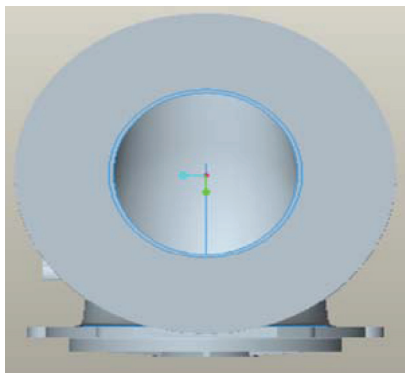

FIGURE 3. 3D model left view of the flange tube

MOLD DESIGN AND ASSEMBLY

The wax pattern injection mold was designed based on the finished drawing specifications. The 3D model of the as-cast blank was created and the mold cavities were created as follows. The model of the part (i.e. the as-cast blank) was imported into the Pro/E assembly module and a 5-workpieces of specified dimensions were created thereby making the bottom and top parts (i.e. lower and upper cavities), the sides' part (left and right) and front part of the mold using cutout method. After considering all the tolerances ± 0.025 , ± 0.25 , ± 0.3 , draft angles of 200° and 250° , shrinkage allowance as well as machining processes, the other components such as the sprue, pins, clamping nuts and studs, screws, etc. were separately modelled based on standard sizes and shapes as required for mold assembly and the whole components were assembled using the Pro/Engineer. Figure 4 shows the unexploded and exploded assembly views of the mold.

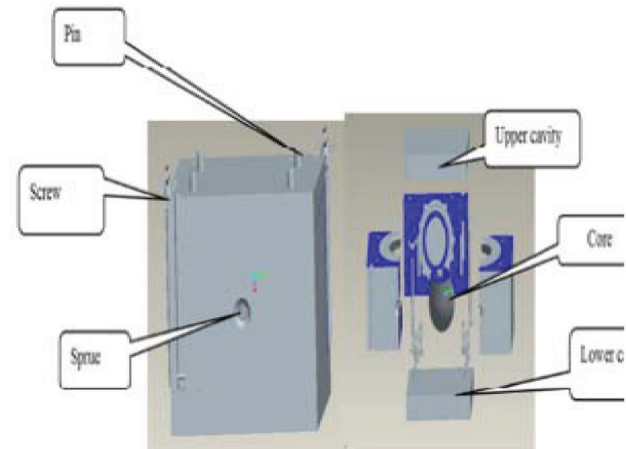

FIGURE 4. Unexploded and exploded assembly view of the mold

COMPUTATION OF MACHINING PARAMETERS

The machining of the flange tube include milling, drilling and reaming. Table 2 shows the process sequence of the machining process. The spindle speed for the milling operation can be computed using:

$$N = \frac{1000V}{\pi D} \quad (1)$$

Where N = spindle speed in rev/min, V cutting speed in m/min and D is cutter diameter. V is selected as 150 m/min and $D = 60$ mm. This selection was based on the material property and the cutting tool (uncoated carbide) selected.

Basic time of milling operation is given by:

$$T_b = \frac{L + 2A}{F \times N} \quad (2)$$

Where T = basic time in minute, L = length in mm, A = approach and F = feed rate in mm/rev and it is expressed as

$$F = f \times n \quad (3)$$

Where f = is feed/tooth and n = number of teeth of the cutter. f was selected as 0.15 mm/tooth and $n = 10$

$$L = \pi D \quad (4)$$

Where D = workpiece diameter.

Basic time for drilling and reaming time are expressed as:

$$T_b = \frac{L + 2A + C}{N \times F} \quad (5)$$

Where $c = \frac{D}{2} \phi$; D is diameter drill of the hole and $\phi = 0.5$ drill point angle ϕ was selected to be 90° but N is 1/3 of the drilling operation. V was chosen as 15 m/min and F as 0.18 mm/rev

Auxiliary time is expressed thus 4

$$T_a = 0.2 \times T \quad (6)$$

Where T_a is the auxiliary time and T is the basic time in minute.

Operation time is thus:

$$T_o = T_b + T_a \quad (7)$$

TABLE 2. Process sequence

Mount	S/N	Description	To (min)
1	1	Mill dia. 164.5 mm	0.72
	2	Drill 9 hole o dia. 7.39 mm	3.51
	3	Ream 9 holes dia. 7.39 mm	10.4
	4	Mill dia. 146.05 mm	0.84
2	1	Drill dia. 22.86 mm	0.53
	2	Ream dia. 22.86 mm	1.56
3	1	Mill dia. r 196.55 mm	0.86
4	1	Mill dia. 82.3 mm	0.40
	2	Drill 3 holes dia. 1.5 mm	0.32
	3	Ream 3 holes dia. 1.5 mm	0.99
	4	Drill dia. 20.32 mm	1.04
	5	Ream dia. 20.32 mm	3.09

DESIGN OF DEDICATED FIXTURES FOR MACHINING THE PART

With the coming of CNC machining technology and the potentiality of multi-axis machines to perform multiple operations and reduce the number of set-ups, the fixture design task has been to some extent simplified in terms of the number of fixtures that would need to be designed. Nonetheless, there is a need to address the faster response and shorter lead-time required in designing and constructing new fixtures. There are problems associated with machining of flange tube, which are poor accuracy, repeatability and unavailability of fixture for machining the flange tube. The machining of flange tube by the use of fixture varies from industry to industry due to dimensional requirements by these industries. To design fixtures for machining the flange tube the following steps were followed: analytical design, 3D modeling and fixture assembly. The analytical design of the fixture entails design of base block or plate, v-blocks, protective plate, keys, pins, auxiliary supports as well as screws. 3D modeling in Pro/E is concerned with all the detail parts of the fixture like base block, v-blocks, pins, screws, keys and supporting clamp. In the fixture assembly, the detailed parts of the fixture generated are assembled systematically. To design the base block of the fixtures, consideration of the machine tool table specifications should be accounted for. This is because the fixture would be mounted on the machine tool table and thus the dimensions of the table is an important factor while designing the base block.

To design the first fixture for milling, drilling and reaming of the nine holes, a base block of dimension 800 mm by 500 mm was created to maintain spatial relationship between the components of the fixture. Then two blocks of V-shapes of length 300 mm, height 70 mm and width 85 mm were designed. One these is fixed and the other is movable. On

the fixed v-block the non-machined surface would be placed and the movable would hold the surface to be machined. To the movable part is a handle for easy pulling out and pushing in of the surface before, during and after processing. These blocks act as locators of the flange tube, which constrain its motion thereby ensuring its position in the fixture. In between the fixed V-block is a plate of thickness 200 mm to protect against damage due to placement, heat, wear and ejection of the workpiece. A clamp is a force-activating mechanism of the fixture. The forces exerted on the part by the clamp hold the part securely in the fixture against all external forces. Auxiliary clamp to support the flange tube during machining has been designed. The auxiliary clamping support has a threaded shape at one of its ends so that it can be screwed and unscrewed before and after machining respectively. Six screws as well as four pins were designed according to standard specifications to get the fixture assembled as shown in figure 5. After machining this surface, the other part was machined using the same fixture. For the drilling of the four holes and milling of the surface where these holes exist, a second fixture was designed as above. Here four screws and two pins were designed based on standard specifications for assembling the fixture. The figure 5, figure 6 and figure 7 show the fixture's 3D, 2D front view and 2D top views respectively of the first fixture while figure 8, figure 9, figure 10 and figure 11 indicate the 3D, 2D front, 2D top and 2D side views of the second fixture, respectively.

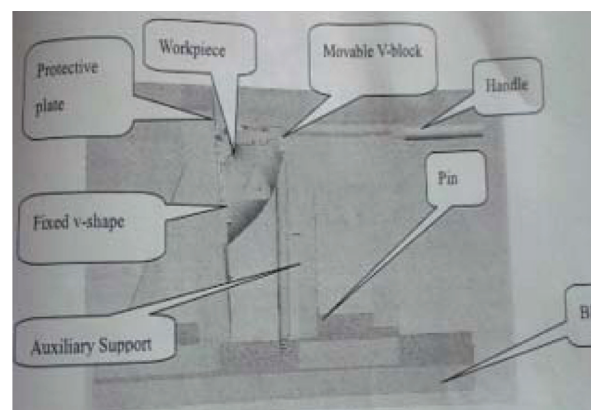

FIGURE 5. 3D of the first fixture

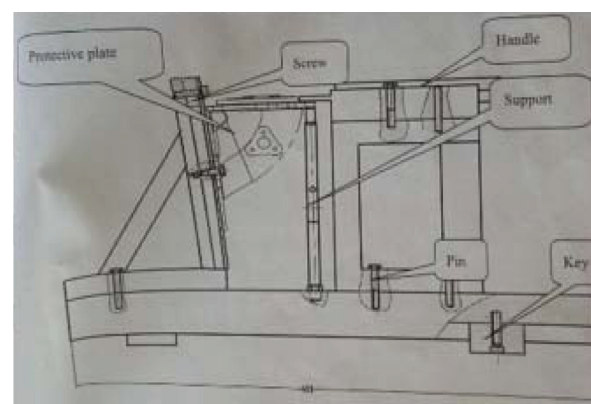

FIGURE 6. 2D Front view of the fixture

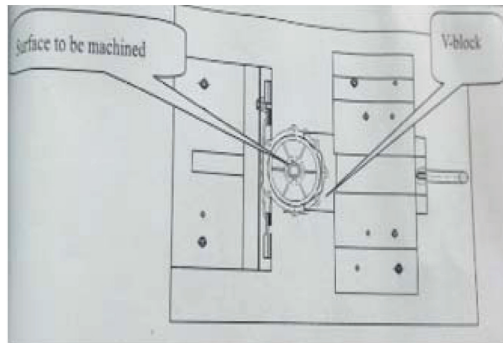

FIGURE 7. 2D Top view of the fixture

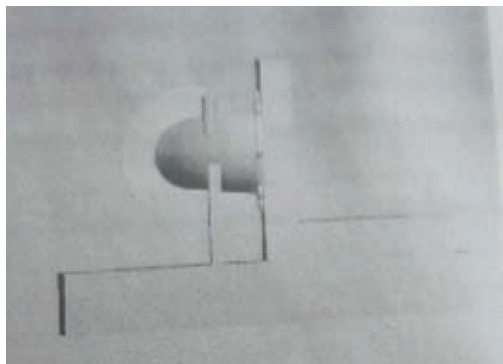

FIGURE 8. 3D of second fixture

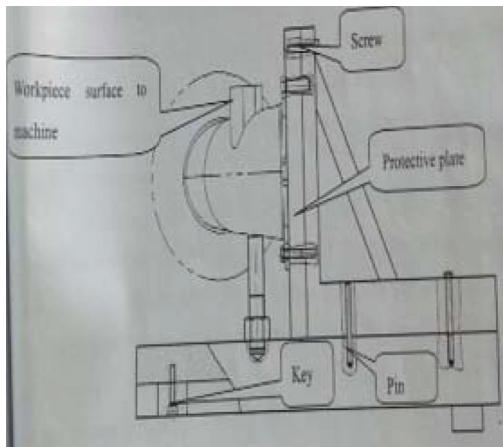

FIGURE 9. 2D Front view of the fixture

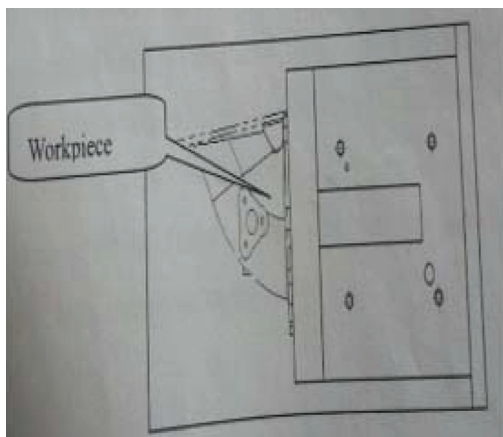

FIGURE 10. 2D top view of the fixture

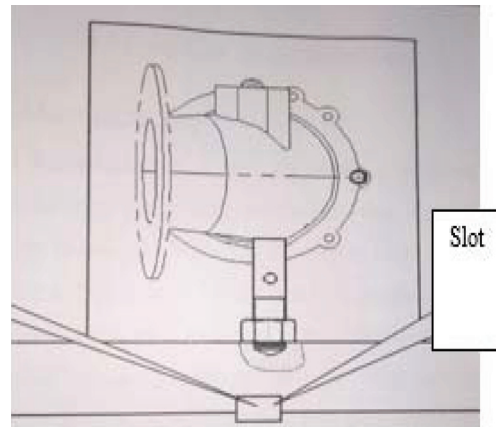

FIGURE 11. 2D Side view of the fixture

MOLD CAVITY SIMULATION

The mold was made up of four components and each has been machined with MasterCAM 9.0. The following steps have been performed to achieve the above. Pro/E generated the entities into IGES format in order to interact with the MasterCAM 9.0. In the MasterCAM 9.0, the IGES format was transformed and rotated and translated in order to convert the unit and ensure that the Z-axis is vertical. Then the machine boundary was set up and a rectangle created so that the flange tube is within machining boundary. Machining parameters such as spindle speed, feed rate, retract angle etc. were entered. The CAM software was played to obtain the tool path and the finished part. Figure 12 shows toolpath generated while figure 13 indicates finished operation. The finish parameters have been inputted into MasterCAM 9.0 and played to visualize the simulation of the flange tube. However, here only two parts of the simulated flange tube are shown.

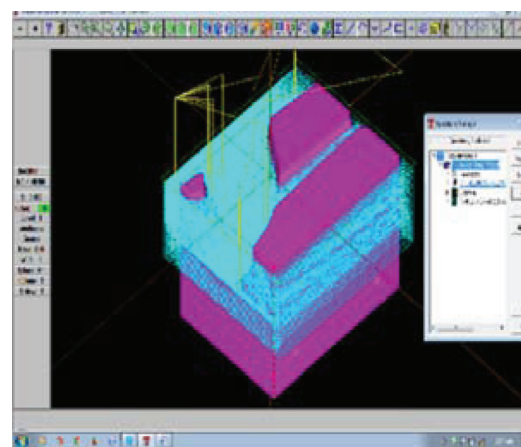

FIGURE 12. Toolpath

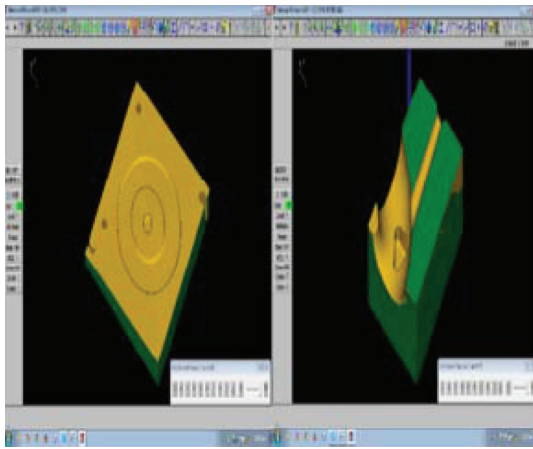

FIGURE 13. Finished operation

RESULTS AND DISCUSSION

CAD/CAM is a useful tool in the manufacturing industry that components difficult to manufacture can be easily made without actually converting the raw materials thus saving time, cost and energy. CAD has been applied to model the flange tube, its mold and fixture for manufacturing. This gives us an insight into how the flange tube will look like in real time enabling the modification of the mold structure and its components. The two dedicated fixtures designed and created can be used to manufacture thousands of flange tube as all factors that affect the durability of the fixture have taken into cognizance. Such factors include support, clamping, positioning and fixture body. The fixtures were designed in such a way that the machinist will operate it without causing him fatigue. From the table 2 machining operation times for the various machining processes was provided. It seen that for the milling operation as the diameter of the workpiece is large the operation time is higher and vice versa. For the drilling and reaming operations increasing diameter of the workpiece increased the operation time but operation time for the reaming is higher than the other operations times and this is due to lower spindle speed. The times indicated that machining operation time is reasonably smaller suggesting faster production rate thereby saving energy, time and cost. For the validation of the simulation, G and M codes part programming should be written and the written part program executed on the computer machining center. This would give the real or actual part of the simulation model.

CONCLUSION

In this article CAD/CAM tool has been applied in the design of machining process and tooling devices for a flange tube and the following conclusions are drawn: A CAD tool, Pro/E has been applied in the creation three-dimensional (3D) model of the flange. The same software was used to design and create a mold and its component parts for the manufacture of the modeled part. Machining process for the production of the part has been designed. Fixtures to support and locate

the flange tube in a machine tool has been designed using the same Pro/E software. CAM tool, MasterCAM 9.0, has been applied to simulate the manufacturing environment for the flange tube. The simulation of the part could be validated by executing G and M codes. It was shown that CAD/CAM tool such as Pro/E Wildfire 4.0 and MasterCAM 9.0 have the capacity to optimize manufacturing operations thus allowing manufacturing flexibility, responding to consumers' requirements and demands, improving products' quality, minimizing cost of production and shortening product development cycle.

ACKNOWLEDGEMENT

The authors would like to thank Kano State Government for sponsoring our education under the foreign training programme.

REFERENCES

- Anna, B., Edward, C., Tomasz, N. & Agnieszka, T. 2009. *Intelligent systems in production engineering and maintenance*. Springer.
- Bruce, G. L. 1987. Manufacturing tolerance cost minimization using discrete optimization for alternate process selection. Brigham Young.
- Chwastyk, P. & Kolosowk, M. 2012. Integration CAD/CAPP/CAM system in design process of innovative products. *International Proceeding Conference 23rd International Symposium DAAAM*, 0397-0400.
- Farin, G., Hoschek, J. & Kim, M.S. 2002. *Handbook of computer aided geometric design*. North Holland.
- Farin, G. 2002. *Curves and surfaces for CAGD: A practical guide*. Morgan Kaufmann.
- Ginting, A. & Haron, C.H.C. 2005. A computer integrated manufacturing system for low repetitive and high product-mix components. *Jurnal Kejuruteraan* 17: 101-12.
- Hargrove, S.K. 1995. A systems approach to fixture planning and design. *The International Journal of Advanced Manufacturing Technology* 10(3): 169-82.
- Hunter, R., Guzman, M., Möller, J. & Perez J. 2006. Implementation of a tolerance model in a computer aided design and inspection system. *Journal of Achievements in Materials and Manufacturing Engineering* 17(1): 345-48.
- Kalpakjian, S., Schmid, S.R. & Musa, H. 2010. *Manufacturing engineering and technology*. Sixth edition. Pearson Education.
- Kassim, J., Rizauddin R. & Abdul Hadi A. 2018. A Review on geometrical tolerance applications in the automotive industry (Satu ulasan terhadap aplikasi toleransi geometri dalam industri automotif). *Jurnal Kejuruteraan SI* 1(6): 41-48.
- Kong, J. & Song, Y. 2013. Analysis on the application of modern manufacturing-oriented CAD/CAM. *Journal of Theoretical and Applied Information Technology* 50(3): 541-47.

- Krogstie, L. Michael S. J.W., Sandro, W. & Kristian M. 2015. Towards a more comprehensive understanding of tolerance engineering research importance. *Procedia CIRP (13th conference on Computer Aided Tolerancing)* 2015, 29-34.
- Liao, D.M., Zhou, J.X., Chen, L.L., Shen X. & Gong X.D. 2011. Casting CAD/CAE automatic optimal riser design technology. *International Journal of Cast Metals Research* 24(3/4): 247-252.
- Mattson, M. 2009. *CNC Programming: Principles and applications*. First Edition. Cengage Learning.
- Mervyn, F.A., Senthil K. & Nee A.Y.C. 2006. Fixture design information support for integrated design and manufacturing. *International Journal of Production Research* 44(11): 23-37.
- Nadeem, S.K. 2011. Generalized statistical tolerance analysis and three dimensional model for manufacturing tolerance transfer in manufacturing process planning. Ph.D Thesis Arizona State University Tempe, AZ, USA.
- Narayan, K.L., Mallikarjuna Rao, K. & Sarcar, M.M.M. 2008. *Computer aided design and manufacturing*. PHI Learning Pvt. Ltd.
- Naumov, A. & Pandilov, Z. 2015. Benefits of implementation of flexible automation and CAD/CAM systems in metal processing companies. *Mechanical Scientific Engineering Journal* 33(1): 91-102.
- Pachbhai, S.S. & Laukik P.R. 2014. A Review on design of fixtures. *International Journal of Engineering Research and General Science* 2(2): 126-46.
- Peshatwar, S.V. & Raut L.P. 2014. Computer aided fixture design for machining of key-ways on eccentric shaft. *International Journal of Scientific & Engineering Research* 4: 648-656.
- Radhaakrishnan, P., Subramanyan, S. & Raju, V. 2008. *CAD/CAM/CIM*. Second Edition. New Age International.
- Ravi, B. 2008. Casting simulation and optimisation: benefits, bottlenecks, and best practices. *Indian Foundry Journal* 2-15
- Shailesh, S. P. & Laukik P.R. 2014. Design and development of hydraulic fixture for machining hydraulic lift housing. *International Journal of Mechanical Engineering and Robotics Research* 3(3): 204-214.
- Sulaiman, N.A., Deqiang, Z., Usman, M.M. & Ahmad A.S. 2018. Application of CAD/CAE tools in the analysis of plastic injection mould. *Journal of Advanced Resaerch Design* 40(1): 1-8
- Usman, M. M., Abdulrahaman, S. A., Nuhu, A. S. & Musa, A. I. 2016. Application of CAD/CAM tools in the production of investment casting part. *IOSR Journal of Mechanical and Civil Engineering* 13(1): 1684-2278.

