

Design and Development of a DAST Based on 2RPS-1S Parallel Mechanism

Fahisal Abdullah¹, M. Arkam C. Munaaim², Mohd Shuhanaz Zonar Azalan¹ and Siti Marhainis Othman¹

¹*School of Mechatronic, Universiti Malaysia Perlis, Malaysia.*

²*School of Environmental Engineering, Universiti Malaysia Perlis, Malaysia*
fahisal@unimap.edu.my

Abstract— There are a number of process design that available in the literature in order to develop a new parallel mechanism that can be applied to the solar farm. However, the best ways to develop a new mechanism still have a challenge. Therefore, this project provides a systematic process design with include the kinematics derivation, mechanical and hardware development, and software development. This project aims to design and development of a Dual Axes Solar Tracking (DAST) based on 2RPS (Revolute-Prismatic-Spherical) -1S (Spherical) parallel mechanism by implementing the systematic process design. The focus is on a two degree-of-freedom (DOF) parallel mechanism – which encloses a closed loop in the structure. Based on MATLAB simulation and real prototyping motion result is show that the movement position of the solar panel has similarity. In summary, both method simulation and prototyping are able to represent a two DOF parallel mechanism. At the same time, the comparative analysis is able also to validate the equation of kinematics that derives from Denavit-Hartenberg (DH) methods.

Index Terms—Kinematics; Parallel Mechanism; MATLAB; Dual Axes Solar Tracking.

I. INTRODUCTION

Nowadays, the renewable energy technologies are growing fast, especially using the solar panels that have been extensively used. One of the renewable energy technologies related to the structure of the mechanism that had been explored by many researchers is DAST [1-7]. For instance, the development of a DAST at Ulu Pauh, Perlis with using two direct currents (DC) motors for creating motion of dual axes by using the Lab View Programming software [1]. However, the design of DAST using the series mechanism structure for dual axes had a weakness regarding move a component part of mechanism DAST due to the weight and the ability to sustain for any unnecessary disturbances such as the wind [2]. Besides that, the applications of DAST are mostly used in residences [1]. Therefore, the design of the DAST using a parallel mechanism to utilising at a Kuala Perlis solar farm is still a challenge.

The selection of designs for the DAST mechanism is based on the 2RPS-1S parallel robot is shown in Figure 1[2]. Based on the study of this mechanism 2RPS-1S parallel robot, this mechanism has a capability to perform the motion of 2 DOF, and it has tilt angle more than 30 degree rotation from east to west. Besides that, the structure of this mechanism is straightforward and when the DAST in the rest position, it is seen same with a static panel that using in the Kuala Perlis solar farm. As an example of DAST at rest position is shown in Figure 2[2]. Therefore, based on a previous kinematics study of this mechanism, the development of DAST based on

the parallel robot can be implemented at the Kuala Perlis solar farm.

This paper's objective is to design DAST based on the mechanism of a 2RPS- 1S parallel mechanism to implement at the Kuala Perlis solar farm. To implement the design of DAST, the systematics design base on kinematics, mechanism and hardware, and software development are proposed [8]. The motion of the solar tracking mechanism based on the motion of the sun is a most important characteristic for developing the concept of mechanisms based on parallel structure. To know the characteristic motion mechanism that follows the sun, the systematic design start with inverse kinematics model will be derived. Then the mechanism and the hardware development based on modelling of inverse kinematics will be discussed. To verify the position and orientation of these types of the DAST mechanism, the software development including the control will be developed. Therefore, based on the systematic design, helpful for us to clarify the motion platform which using the DAST mechanism and it is ready to be developed.

This paperwork is planned as follows. Firstly, the descriptions of robot architecture based on two parts which begin 2RPS-1S mechanism and the second part regarding system operation. This is two parts will help to know more detail regarding the characterisation motion of the mechanism that will be used in term of workspace [9]. Next, the implementation of systematics design base on kinematics, mechanism and hardware, software development will be described. This will lead to produces a new design of the structural mechanism of solar tracking based on characterisation motion as shown in the kinematic result. The design structure is actually being developed based on current technology use in the solar farm. The result of comparisons between the kinematic model and design of structured two DOF applied at the solar farm is presented. Further, the performance of design two DOF of 2RPS- 1S mechanism a performed and 3D visual Inventor verification with position and orientation for both kinematics models using a program prepared in MATLAB and design mechanism is conducted. Lastly, the conclusion makes up for this project.

II. ROBOT ARCHITECTURE

The description of robot architecture will consist of two parts: The description of 2RPS-1S mechanism and System operation of the 2RPS-1S mechanism.

A. The Description of 2DOF 2RPS-1S Mechanism

The structure of the 2RPS-1S mechanism parallels manipulator as shown in Figure 1[2]. There is consist of two-

part platform where the top part is called moving platform B where represent triangle $B_1B_2B_3$ and the second part is called a fixed platform A where represent the triangle $A_1A_2A_3$. Two leg 2RPS with linear actuator represent A_2B_2 and A_3B_3 respectively. One bar 1S with no actuator is represented A_1B_1 . Two revolute joints are representing at A_2 and A_3 respectively. Three spherical joints located at the top moving platform where B_1 , B_2 and B_3 respectively. Point O_1 and O_2 is a centre of triangle $A_1A_2A_3$ and $B_1B_2B_3$ respectively. However, based on the information of machine elements such as linkages, prismatic, spherical and revolute joints, the calculation of DOF use Gubler still can't be applied. To find the DOF of DAST mechanism, the platform motion confined by two active legs is analysed [10] and shown in Figure 2[2]. Based on the motion in Figure 2(a), the length of Leg A_3B_3 is higher than Leg A_2B_2 and Leg A_1B_1 . Figure 2(b) is shown the leg A_2B_2 is higher than A_3B_3 and A_1B_1 . Figure 2(c) is shown the leg A_2B_2 , and A_3B_3 is higher than A_1B_1 . Based on Figure 2, the motions Leg A_1B_1 , A_2B_2 and A_3B_3 are acceptable, and the mechanism of the DAST has two DOF.

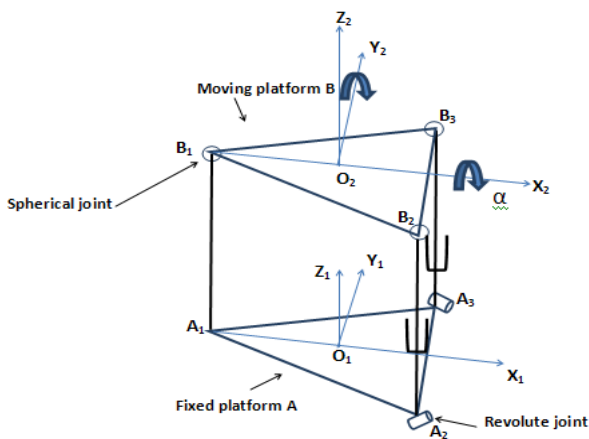

Figure 1: Vector diagram 2RPS-1S[2]

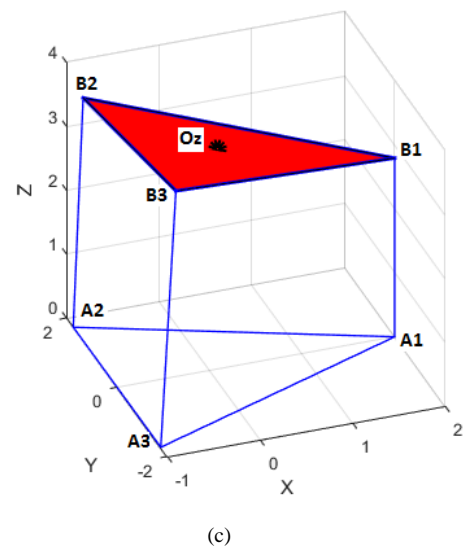
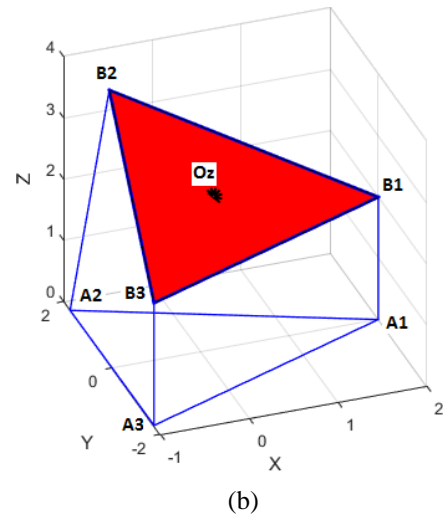
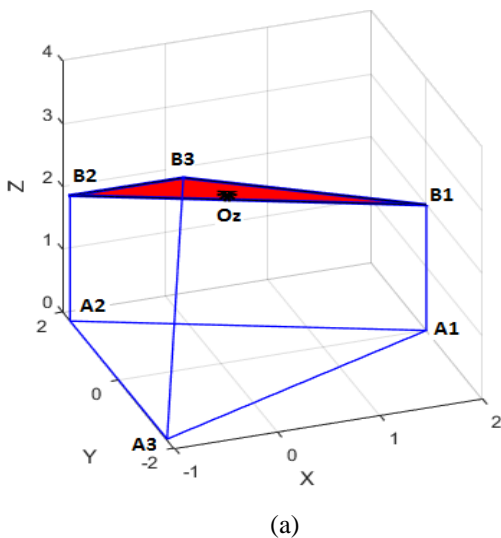

Figure 2: (a) Turn left side position, (b) Turn right side position, (c) Linear position



B. System Operation of the 2RPS-1S Mechanism

The motion of 2 DOF DAST mechanisms refers to the location of the sun can be determined through the information of elevation angle and azimuth angle [11]. Figure 3 shows the location of the sun. In order to organize the leg A_2B_2 and A_3B_3 according to the motion of the sun, the theory of azimuth angle, where a negative value have in the morning with the sun at the east and when the sun in the west, the positive value of azimuth angle will show the afternoon condition, will apply [1]. The hour angle or time of the day with, related to the azimuth angle is indicated the changes by 15° per hour. Regarding that information, one DOF for the leg length difference A_2B_2 is based on 15° per hour when the sun at the east and the leg length difference A_3B_3 is based on the 15° per hour when the sun in the west direction. Another one DOF of DAST mechanism will perform the adjustment of the solar panel's motion in order to get high accuracy when exposed to the sun in both directions.

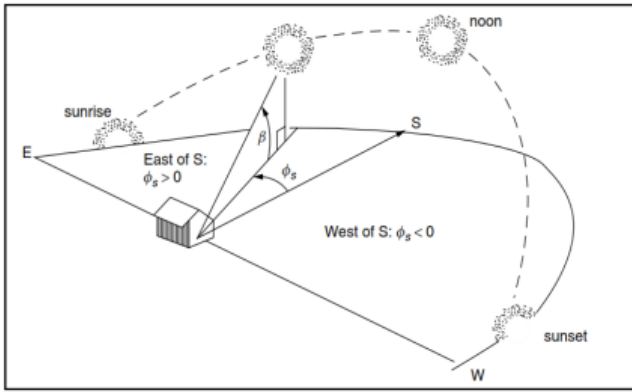

Figure 3: Position of the Sun [1]

III. SYSTEM IMPLEMENTATION

The system implementation consists of three parts: kinematics, mechanism and hardware development and software development (Figure 7).

A. System Kinematics

Kinematics mechanism is studied about the motion without involving the force acting while performing the task. For the DAST mechanism based on 2RPS-1S parallel mechanisms, the inverse kinematics in Equation (1) is derived based on DH method [2]. The kinematics studies derive based on geometry as shown in Figure 4. The chosen of inverse kinematics model because easier to predict the workspaces of DAST based on input pose with, related to the input coordinate x, y and z system. By using the equation 1, the 3D visual motion using MATLAB, such as shown in Figure 2 can be used for studies the behaviour of a workspace motion DAST mechanism [12,13]. The comparisons of 3D visual motion using MATLAB and Inventor 3D mechanism can be performed to validate the motion of DAST.

$$A_i B_i^2 = (C_i + P_x)^2 + (D_i + P_y)^2 + (E_i + P_z)^2 \quad (1)$$

Where:

- $A_i B_i$ is representing a number of legs with $i=1, 2, 3$
- P_x is representing the Cartesian coordinate-x
- P_y is representing the Cartesian coordinate-y
- P_z is representing the Cartesian coordinate-z
- C_i is representing position vector for x-axis
- D_i is representing position vector for y-axis
- Z_i is representing position vector for z-axis

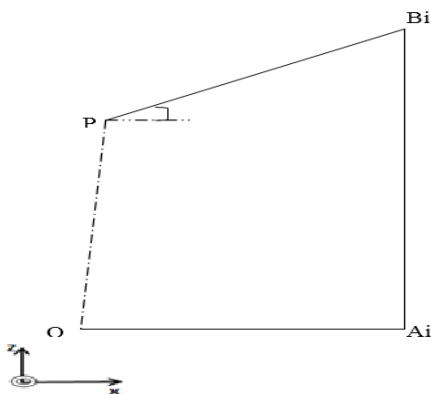

Figure 4: Geometry Diagram of 2RPS-1S

B. Mechanism and Hardware Development

1) Mechanism Development

Figure 5 shows the DAST mechanism from the side view designed in Inventor software. The assembly of DAST mechanism using Inventor software is to validate the equation 1 and at the same time the motion of the mechanism. This can be done by using MATLAB Simulink as shown in Figure 6. The Simulink model using MATLAB can be used to the simulated mechanism and at the same time to understand the behaviour of motion mechanisms[14-16].



Figure 5: 3D Inventor Software

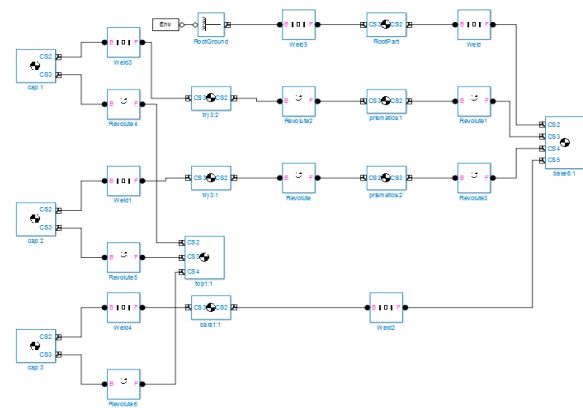

Figure 6: MATLAB Simulink 2RPS-1S

2) Hardware Development

This DAST mechanism was used for linear prismatic joints, PIC 18f4580 microcontroller and driver MD10C is used to move the solar panel as shown in Figure 8. Figure 9 shows the actual DAST mechanism in the testing area. The first leg mechanism was set up to move the solar panel 15° per hour started from 7.00 am facing east by using the first Light Dependent Resistor (LDR) sensor and the length first leg will start from minimum to maximum value. At around 12 pm, the first and second leg mechanism had a same maximum length. The second leg mechanism started to operate function by decrease the length maximum to minimum for rotating the solar panel position from the direction of east to facing the direction of west, and at the same time, the first leg has a maximum length because in the evening the sun position is in the west direction. This DAST mechanism is following the sun movement and back to home position when the second LDRs sensor detects no sun radiance. The linear prismatic joint is the central part of DAST mechanism, to make the motion of 2 DOF.

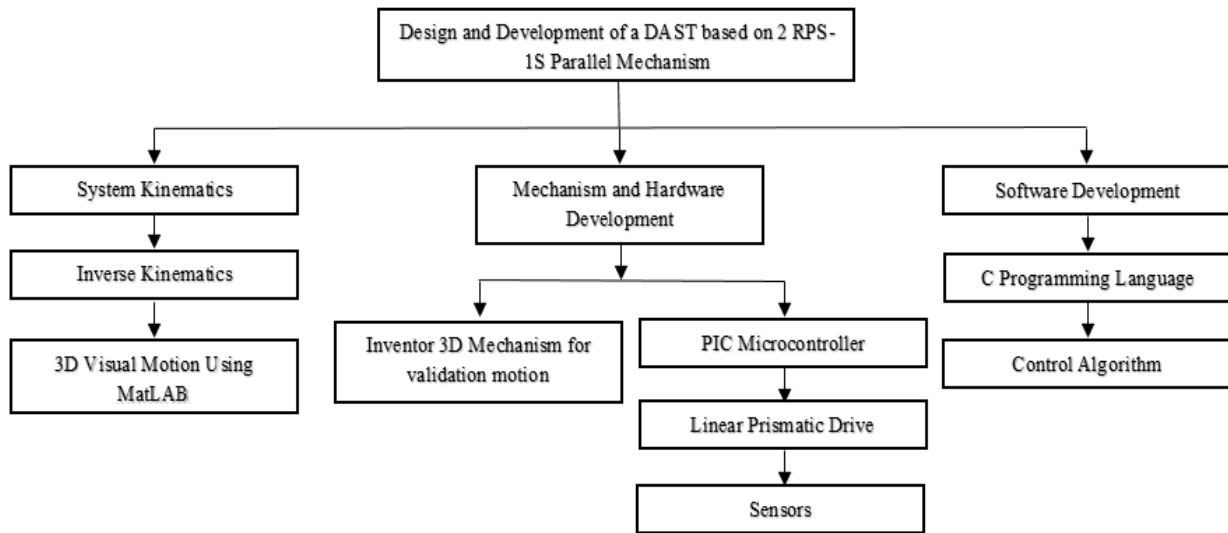

Figure 7: Systematics Process Design

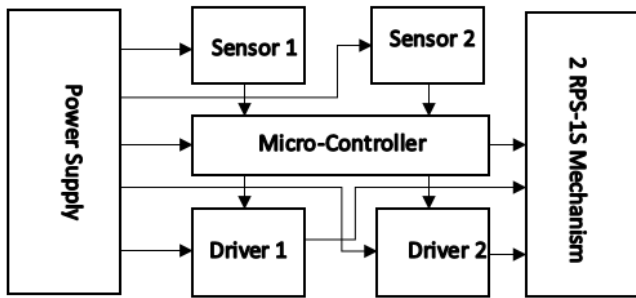

Figure 8: Hardware Architecture of the DAST

moving. If L more than R than the leg A_2B_2 will increase the length and solar panel facing to east. If the solar panel is facing to west direction, that means the L is less than R.

IV. RESULT

Figure 10, 11 and 12 shows workspace motion produce by the DAST mechanism based on 2RPS-1S using MATLAB Simulation and real motion prototyping mechanism. The comparisons motion for simulation and real mechanism are based on analyses the DOF of the platform motion [10]. Based on the simulation and real experiment result, the workspace motion is seen a similar motion at three condition morning, noon and evening.



Figure 9: Real Prototyping 2RPS-1S

3) Software development

Software development consists of the creating the algorithm for control motion linear prismatic joints by using the c- programming that applied in the microcontroller. To move and rotate the solar panel to follows the movement of the sun, the Bang-Bang controller is proposed [17]. The simple algorithm to control the motion of solar panel that follows the movement of the sun is described. In the automatic mode, solar panel motion is based on the movement of the sun from facing west to facing east. It is made by the detection of LDR at the right side and left side solar panel. If the difference between the two LDR sensors, say L and R are same ($L=R$) than solar panel will stop



(a)



(b)

Figure 10: (a) and (b) Position platform at morning condition

V. CONCLUSION

In this project, we share the information regarding the design and development of a DAST using 2RPS-1S parallel mechanisms. This development of mechanism has used systematic process design base on kinematics, mechanism and hardware, and software development will give more value in term of design DAST mechanism. Based on the results show the simulation using MATLAB and real prototyping has a similar motion. In other words, the comparative analysis of motion between real and simulation result will validate the inverse kinematics equation that produces from DH method.

ACKNOWLEDGEMENT

The researchers want to express a great thanks and gratitude to final year student at the School of Mechatronic, University Malaysia Perlis (UniMAP), which makes the success of this project develops. Many thanks to those are fully supported by their free energy to help in term of delivering information that made this project possible.

REFERENCES

- [1] Afiqah, N. N., et al. "Development of Dual Axis Solar Tracking System Performance at Ulu Pauh, Perlis." *Applied Mechanics and Materials*. Vol. 793. Trans Tech Publications, 2015.
- [2] Abdullah, Fahisal, et al. "The feasibility study of applying solar tracking in power plant Kuala Perlis, Malaysia." *Systems, Process and Control (ICSPC), 2016 IEEE Conference on*. IEEE, 2016.
- [3] S. Rahman, R. A. Ferdous, M. Abdul Mannan, and M. A. Mohammed, "Design & implementation of a dual axis solar tracking system," *American Academic & Scholarly Research Journal*, vol. 5, no. 1, pp. 47-54, 2013.
- [4] Alexandru, C., and M. Comsit. "Virtual prototyping of the solar tracking systems." *International Conference on Renewable Energy and Power Quality-ICREPQ. 2007*.
- [5] Lee, J. F., and Nasrudin Abd Rahim. "Performance comparison of dual-axis solar tracker vs static solar system in Malaysia." *Clean Energy and Technology (CEAT), 2013 IEEE Conference on*. IEEE, 2013.
- [6] Othman, N., et al. "Performance analysis of dual-axis solar tracking system." *Control System, Computing and Engineering (ICCSCE), 2013 IEEE International Conference on*. IEEE, 2013.
- [7] Deepthi, S., et al. "Comparison of efficiencies of single-axis tracking system and dual-axis tracking system with fixed mount." *International Journal of Engineering Science and Innovative Technology 2.2* (2013): 425-430.
- [8] Lin, Jonqlan, Ci-Huang Luo, and Kao-Hui Lin. "Design and implementation of a new delta parallel robot in robotics competitions." *International Journal of Advanced Robotic Systems 12.10* (2015): 153.
- [9] Abdullah, Fahisal; Yaacob, Sazali; Basah, Shafriza Nisha. "Comparison of Kinematic Models for Performance Evaluation of Parallel Mechanism." *Australian Journal of Basic & Applied Sciences; 2014 Special*, Vol. 8 Issue 15, p180
- [10] Bi, Zhuming M., and Y. Jin. "Kinematic modeling of Exechon parallel kinematic machine." *Robotics and Computer-Integrated Manufacturing 27.1* (2011): 186-193.
- [11] Bazyari, Shahriar, et al. "A study on the effects of solar tracking systems on the performance of photovoltaic power plants." *Journal of Power and Energy Engineering 2.04* (2014): 718.
- [12] Ciprian, Lapusan, Maties Vistriian, and Hancu Olimpiu. "Workspace analysis and design of a 6-DOF parallel robot." *Proceedings of the 8th WSEAS international conference on Signal processing, robotics and automation*. World Scientific and Engineering Academy and Society (WSEAS), 2009.
- [13] Fahisal Abdullah, Sazali Yaacob, and Shafriza Nisha Basah, "Novel 3-DOF Parallel Mechanism for Bedridden Repositioning System: A Kinematics Analysis," *Journal of Medical and Bioengineering*, Vol. 4, No. 3, pp. 235-238, June 2015. Doi: 10.12720/jomb.4.3.235-238
- [14] Fedák, Viliam, František Ďurovský, and Róbert Úveges. "Analysis of Robotic System Motion in SimMechanics and MATLAB GUI Environment." *MATLAB Applications for the Practical Engineer*. InTech, 2014.



(a)

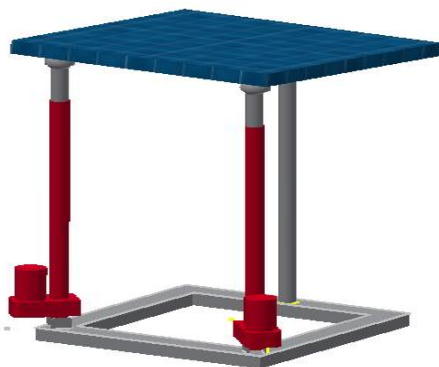

(b)

Figure 11: (a) and (b) Position platform at noon condition



(a)



(b)

Figure 12: (a) and (b) Position platform at evening condition

- [15] Deng, Wenbin, Jae-Won Lee, and Hyuk-Jin Lee. "Kinematics simulation and control of a new 2 DOF parallel mechanism based on Matlab/SimMechanics." *Computing, Communication, Control, and Management, 2009. CCCM 2009*. ISECS International Colloquium on. Vol. 3. IEEE, 2009.
- [16] Vamvu, P., C. Barbu, and M. Pop. "Matlab Virtual Reality Simulations for optimizations and rapid prototyping of flexible lines systems." 11th WSEAS *International Conference on Data Networks, Communications, Computers (DNCOCO'12)*, 7-9 September 2012. 2012.
- [17] Shibasaki, Hiroki, et al. "High speed activation and stopping control system using the bang-bang control for a DC motor." *Industrial Electronics (ISIE), 2013 IEEE International Symposium on. IEEE*, 2013.