

EXPLORING THE VALIDATION OF ISLAMIC HOSPITALITY MANAGEMENT IN TOURISM DESTINATION: MALAYSIAN PERSPECTIVES

Che Musa Che Omar & Mohammad Serazul Islam,
Universiti Kuala Lumpur Business School,
chemusa@unikl.edu.my & seraz_iium@yahoo.com

ABSTRACT

Hospitality symbolizes such kind of act which is consummated by the hosts to welcome and take care of guests or strangers or travelers till they stay at the home of host or any host country. The basic requirement of hospitality is to ensure providing of healthy food, drinks as well as comfortable and safety accommodation for welcomed guests or tourists. Islam always gives more importance and priority on hospitality and Muslims can enhance and increase their societal, national as well as international bondage strongly by dint of hospitality. In Malaysia Islamic tourism and hospitality industry has been potentially developed since Malaysia is enriched with arts, heritage and Muslim Malay culture. Although Islamic hospitality has been studied by many researchers, rare research has been done into the authentication of Islamic hospitality management. So, the main aim of this study is to explore the validation of Islamic hospitality management in the Malaysian tourism destination. A total of 563 Muslim tourists from 35 countries took part in this study. Structural Equation Modeling (SEM) was an appropriate data analysis technique for this study. A self-administrated questionnaire was developed. The 5-likert scale was used in questionnaires. The Cronbach's alpha coefficient was used to test the reliability of the scale. The findings as analyzed by Structural Equation Modelling (SEM) revealed that the overall fit indices showed a satisfactory fit to the empirical data. The criterion of $p < 0.001$ and critical value of $\chi^2 = 59.70$ were used. The ratio was less than 2 and the value .786 showed that the model is fit. The P-value with the ratio more than 0.05 and at the value 0.599, GFI being more than 0.9 at the value of 0.997, TLI with ratio more than 0.9 and value of 1.003, and finally RMSEA's critical ratio less than 0.08 and the value of 0.000 confirm this model to be significant and fit. The parameters were free from offending estimates. The results also contributed toward successful validation of Islamic hospitality management of Malaysian tourism destination. The significance of this study stands on its contribution to validate Islamic hospitality management; and it could be applied by future researchers in the various countries.

Keywords: *Destination, Islamic Tourism, Hospitality Industry, Modelling*

INTRODUCTION:

Hospitality denotes to such kind of action which is accomplished by the hosts to welcome and take care of guests or strangers or travelers until they stay at the home of host or any host country. Actually the basic requirement of hospitality is to ensure providing of healthy food, drinks and comfortable and safety accommodation for welcomed guests or tourists. In other words, the term „hospitality“ reminds the act of building relationship between host and guest. This word „hospitality“ has been derived from „hospitaire“ which is a Latin word and the meaning of it is „receiving guest“. Nevertheless hospitality is a process of demonstrating love, respect, honor and kindness towards guests or tourists. Islamic hospitality is overprotecting the guest to feel the most comfortable and relaxed in any kind of situation with the guidance from al-Qur'an and Hadith.

In the Holy Qur'an Allah (swt) declares,

“O you who believe! Give of the good things which you have [honorably] earned, and of the fruits of the earth which we have produced for you... And whatever you spend in charity or devotion, be sure Allah knows it all. (Al-Baqarah: 267–270)”

It is reported that Prophet Muhammad (saw) said, “The guest’s reward is to be provided with a superior type of food for a night and a day, and a guest is to be entertained with food for three days; whatever is offered beyond that is regarded as a charitable gift. And it is not lawful for a guest to stay with his host for such a long period so as to put him in a critical position” (Al-Bukhari). In another established shahi hadith Prophet Muhammad (saw) said, “Hosting a guest for at night is the duty of every Muslim. Whoever comes to his courtyard in the morning, he owes him (hospitality) if he (visitor) may ask for his right and if he wishes, he may refrain” (Sunan Abu Dawud). Islam always gives more importance and priority on hospitality because by dint of it Muslims can enhance and increase their societal, national as well as international bondage strongly.

According to Samori and Rahman (2013) in Malaysia Islamic tourism and hospitality industry has been potentially developed since Malaysia is enriched with arts, heritage and Muslim Malay culture. In order to promote tourism and hospitality industry as a distinguished industry the first and foremost requirement is to implement Islamic approach in this industry.

Recently in Malaysia “it has been observed that there is a growing interest in a new tourism concept such as „Islamic tourism“ or „halal“ hospitality” (Samori & Rahman, p.96, 2013). Tourism industry in Malaysia demonstrates certain Islamic approaches for providing hospitality to the tourists nationally and internationally. Moreover after the attack of September 11, 2001 Arab and Muslim travelers’ travelling destinations were tremendously changed. Now they prefer to travel through-out the Muslim countries instead of travelling in UK, US and European countries. Malaysia has become their first choice to visit.

In other words halal thing is the fundamental demand of every sector in each Muslim country. Likewise Malaysia introduces halal goods such as food, manufacturers, pharmaceuticals, cosmetics, wrapping and logistics merchandises as well as halal world-wide services as the key and staple components in terms of tourism and hospitality industry in Islamic approach. Samori and Rahman (p.95, 2013) cite “it has been a goal of the Malaysian government to establish Malaysia as a global halal hub for halal products and services to the Muslim countries all over the world”.

1. The Halal Master Plan

Basically, the Halal Master Plan is made based on the Islamic laws and values. Therefore, the Halal Master Plan refers to have certain Islamic issues related to tourism i.e. “the issues of certification, sectoral development, halal integrity, implementation, time frames and responsibilities, projecting the country’s international image as an authority in halal products matters” (Shafaei, & Mohamed, 2015, p. 100). Here the Halal Master Plan lengths three segments those are namely

Phase 1: 2008-2010 for developing Malaysia as a global center for halal integrity and preparing the industry growth;

Phase 2: 2011-2015 for establishing Malaysia as one of the preferred locations for halal-related business; and

Phase 3: 2016-2020 for broadening geographic foot print of home-grown halal-related companies (Saifol, 2011).

Global Muslim Travel Index (GMTI) 2018 Results

In the Global Muslim Travel Index (GMTI) 2018 Malaysia is in the first position among all Muslim friendly destinations. In terms of varies criteria and facilities Malaysia has proved itself as one of the best and most attracting destinations for the Muslim tourists. Secondly, the Indonesia is in the second top position like previous year and Indonesia occupies the third position among the top 10 OIC Destinations and these destinations are shown in the following Table 1:

Table 1: Top 10 OIC Destinations and Malaysian Ranking 2018

RANK	GMTI 2017 RANK	Destination	Score
1	1	Malaysia	80.6
2	2	Indonesia	72.8
3	3	UAE	72.8
4	4	Turkey	69.1
5	5	Saudi Arabia	68.7
6	6	Qatar	66.2
7	7	Bahrain	65.9
8	8	Oman	65.1
9	9	Morocco	61.7
10	11	Kuwait	60.5

Source: Mastercard-Crescent Rating Global Muslim Travel Index (GMTI) 2018

2. Accommodation for the Muslim travelers

All tourists who come to certain countries from different parts of this Universe; first of all they must need a temporary living place, foods, and drinks. Then they need markets to buy their expected things, historical places to visit and to know the history of certain country, attractive natural scenario to enjoy and to get relief from the daily monotonous life and above all to know the creation of Allah (SWT).

Moreover, living place for the Muslim travelers indicates Hotels which are constructed for the temporary residence of the tourists. In these Hotels “facilities should be operated based on shariah principles” (Shaيدا, Rahman, Awang, Man, 2011). To make a shariah-complaint living place for the Muslim tourists some requirements of Hotel must be implemented based on Islamic approaches. For example, Henderson suggests (2010) the following things for an Islamic Hotel which are included based on Islamic approaches:

“• No alcohol

- Halal food only
- Quran and prayer mats available in each room
- Beds and toilet positioned so as not to face the direction of Mecca
- Bidets in the bathrooms
- Prayer rooms
- Appropriate entertainment
- Predominantly Muslim staff
- Conservative staff dress
- Separate recreational facilities for men and women
- All female floors
- Guest dress code
- Islamic funding” (Henderson, 2010)

In the Table 2 below, it is clearly displayed that a total of 283 Muslim-friendly hotels exist throughout the 14 states of Malaysia. All these hotels have been certified as Halal by JAKIM. Kuala Lumpur occupies the first position having 44 hotels those are certified as Muslim friendly hotel followed by Johor, Selangor, Penang and Sabah. Although the locations of these hotels are far from each other among the 14 states of Malaysia, all of these hotels offer a Muslim-friendly and safety accommodations for Muslim tourists. It can be argued that in the tourism and hospitality industry hospitality is the most important demand among all.

Table 2: Number of Muslim-Friendly Hotel in Malaysia

No.	Malaysia States	Number of Muslim-Friendly Hotel
1	Kuala Lumpur	44
2	Johor	33
3	Melaka	22
4	Negeri Sembilan	23
5	Pahang	14
6	Selangor	32
7	Perak	15
8	Penang	30
9	Kedah	11
10	Perlis	N/A
11	Terengganu	13
12	Kelantan	3
13	Sabah	28
14	Sarawak	15
	TOTAL	283

Source: Muslim-Friendly Hotels, Islamic Tourism Centre Malaysia (2015)

3. Tawhidic Value-Laden Market

The market for Islamic tourism should be Tawhidic value-laden. In every Muslim majority country there should be built market based on Islamic approaches so that travelers can be benefitted by purchasing products from the Tawhidic value laden market. In this market every product must be halal and haram products should be rejected. Ala al-Hamarneh (2011) states, “The emerging of a fast growing middle class and the social acceptance of international tourism as recreational activities in Muslim societies are opening wide possibilities for an intra-Islamic tourism market”.

Hence if the Islamic approaches can be applied and established authentically in tourism and hospitality industry then it would be easier for the Muslim travelers to visit throughout the world. Wherever they want to go to spend their leisure period tourism and hospitality industry in Islamic approaches must have to be there. The act of travel in Islam is considered as a “purposeful” activity which puts great emphasis on Islamic motivations as acting in the cause of God (fi-sabilillah), submission to the ways of God (through the Hajj and the Umrah), realization of the smallness of man and the greatness of God, encouraging and strengthening the bond of siltaturrahim (Muslim fraternity) and conducting business (Din, 1989).

4. Challenges to promote hospitality guidelines in tourism industry in Malaysia

The major challenge of developing tourism and hospitality industry in Islamic approaches depend on the contribution of this tourism industry to remove poverty and also to develop the socio-economic situation of any country. According to High-level Intergovernmental Meeting on Sustainable Tourism Development (2005) poverty reduction which is linked with the tourism development is observed in the context of the process of tourism development for increasing socio-economics benefits, distributing the benefits in most of the part among the societies especially among the poor individuals, minimizing argumentative impressions, providing the essential support to advance sustainable tourism development.

Furthermore, High-level Intergovernmental Meeting on Sustainable Tourism Development (2005) considers that Countries and areas in the region of Asia and the Pacific face a particular set of major challenges and issues for developing tourism sector, and the meeting also highlights five major issues:

1. “Enhancement of tourism role to develop socio-economic and reduce poverty.
2. Facilitate travel and develop transportation as well as other infrastructure related to tourism
3. Tourism for socio-cultural and environmental management.
4. Tourism crisis and risk management.
5. Develop human resources in the tourism sector” (High-level Intergovernmental Meeting on Sustainable Tourism Development, 2005).

Liu (2006) explores the policy background of encouraging rural tourism development and it also highlighted some impeding issues and features of rural tourism community. She (2006) finds that due to insufficient attention of building local capacity, disinclination to the integration of local settlements and misplacing the perception of local professionalism, tourism development paradox has been taken place in Kedah in Malaysia. Amran Hamzah and Hampton (2011) discuss on the challenging situation of a small Island Kecil in Malaysia. They deliberate regarding the key moment of Kecil when backpacker tourism destination changes to a different tourism form from small scale. They (2011) find two factors namely the changing planning environment and the characteristics of local entrepreneurs.

Likewise in Malaysia there exist “some barriers to develop Islamic tourism- inadequate research activities, appropriate images, proper policy and guidelines, marketing problems and lack of coordination” (Bhuiyan, et al., 2011, p. 1333). Hence, sometimes it is noticed that some Muslim travelers intend to travel evading Islamic approaches. Despite of having knowledge on Islamic approaches they do not want to apply these approaches during their travel. In other words, instead of determining their travel purpose as ibadah, dawah, jiarah, visiting Islamic historical places they indicate their travel purpose as business, shopping, visiting friends and so on.

Beside these Bhuiyan, et. al. (2011) comment that Malaysia fails to develop communal policy and strategy for developing Islamic tourism and hospitality industry based on Islamic approaches. According to them Malaysia has not build up appropriate relationship internationally in developing tourism and hospitality industry in Islamic approaches. Consequently, “Due to proper marketing strategy, Islamic tourism could not focus highly among the tourists” (Bhuiyan, et al., 2011, p. 1338) all over the Muslim worlds. So it is relevant to examine the barriers which are the hindrance for common tourism and hospitality development as well as the development of tourism and hospitality industry in Islamic approaches.

5. Methodology

In this study, a descriptive questionnaire survey was firstly used, and then was involved a structured questionnaire given to the respondents, which was designed to produce specific information. This study followed the structured data collection; a formal questionnaire was set up and the questions were asked in a prearranged order, in consequence the process was also direct. According to Malhotra (2004) survey questionnaires may be administered in four major modes which include telephone interviews, personal interviews, mail interviews and electronic interviews. However, in the survey method, respondents are asked with a variety of questions regarding their behaviour, intentions, attitudes, perceptions, awareness, motivations and demographic and lifestyle characteristics (Malhotra, 1999).

In this study, the survey was conducted in various places. The main focus of this study was to confirm the effect of Islamic approach for developing tourism and hospitality industry in Malaysia. A scale for Islamic approach was produced from this study.

Descriptive analysis was used in first stage of this research to determine the occurrence of various phenomena in this study. To minimize the errors and maximize reliability, the survey required a structured questionnaire and an appropriate number of respondents (Kinnear and Taylor, 1996). In

this research, the 7-likert scale was used in questionnaires. Indeed respondents completing the questionnaires in this research were allowed to place their answer anywhere along the 7-likert scale. Many social scientists accept that likert scales are approximately interval in character (Aasker, et al, 2000). In brief, the scale is much an interval scale as the respondents themselves wanted it to be. Finally, a ratio scale possesses all the properties of the above three types of scales (Malhotra, 1999) because ratio scales allow the research to identify and rank the objects and compare intervals or differences (Farzel, 1997).

SAMPLING

Data was collected through distributing structured questions to the international Muslim tourists of various backgrounds in three different states (Lankawi, Penang and Kuala Lumpur) of Malaysia. The respondents of the main study were selected by using disproportionate stratified random sampling procedure. Sekaran (2003) indicates that sample sizes between 30 and 500 could be effective depending on the type of sampling design used and the research question investigated. So, in this study 650 samples was used to complete the thesis.

DATA ANALYSIS

The data analysis of this study was organized into four stages, as shown in using descriptive and inferential statistics techniques. Data was coded and analysed by using the statistical packages for social sciences.

Stage i – Descriptive Analysis

The first stage of the data analysis used means, standards deviations, the techniques of frequency and percentages to present the respondent's frequency in developing their demographic profile.

Stage ii – Exploratory Factor Analysis

The second stage of the data analysis was conducted an exploratory factor analysis (EFA) to identify the factor structure for measuring the Islamic approaches of Muslim tourists for the development of tourism and hospitality industry in Malaysia. Therefore, these constructs were elaborated and then checked the validity and the reliability of the scale. The decision was to consider a factor as significant was identified by a factor loading greater than 0.35 and greater than 1.0 Cronbach's alpha coefficient was used to test the reliability of the scale.

Stage iii – Confirmatory Factor Analysis

The third part of the data analysis employed a confirmatory factor analysis (CFA) to confirm the factor structure for analysing the Islamic approaches of Muslim tourists for the development of tourism and hospitality industry in Malaysia, and check the validity and reliability of the measuring scale.

Confirmatory factor analysis (CFA) allows manifesting variables to be free to load on specific factors. The model is then evaluated by statistical means to determine the adequacy of its goodness of fit to the data (Byrne, 2010). Specifically, the researcher can determine whether or not a pattern of correlations for a set of observations is consistent with a specific theoretical formulation. In this study, the goodness of fit testing was conducted by using several criteria, including chi-square test, root mean square error of approximation (RMSEA), Tucker-Lewis Index (TLI/NNFI), goodness of fit index (GFI), adjusted goodness of fit index (AGFI), parsimony normed fit index (PNFI), and comparative fit index (CFI).

Stage IV – Structural Equation Modelling (SEM)

The fourth part of the data analysis identified the structural relationships between the factors involvement and strategies towards Islamic tourism and hospitality industry in Malaysia. This path analysis technique enables estimating simultaneously multiple regression equations in a single framework. All direct and indirect relationships in the framework were estimated simultaneously. Thus, the method allowed all the interrelationships among the variables to be assessed in the same decision context. In order to test the fitness level of the framework, the goodness of fit measures was included in the analysis.

6. Tourism & Hospitality Credibility

Based on Table 3, the present study confirmed acceptable reliability of tourism and hospitality with a number of item measurements is 9. This study also configured a detail reliability test for each item if the item deleted. It's confirmed an acceptable level of reliability for item number 1 until 9 (table 4). The consistency of indicators has a significant interaction as reliable measurements of tourism and hospitality. The reliability test is useful to confirm all measurements of variable and all indicators were involved further with a confirmatory factor analysis (CFA) process for composite reliability and hypothesis testing.

Table 3: Reliability statistic of tourism & hospitality

Variable	Cronbach's Alpha	No. of Items	Remark
Hospitality	0.719	9	Acceptable

Table 4: Item-total statistic of Tourism & Hospitality credibility

Items	Cronbach's Alpha if item deleted	Corrected Item-Total Correlation	Remark
T & H1	0.684	0.474	Acceptable
T & H2	0.674	0.542	Acceptable
T & H3	0.668	0.584	Acceptable
T & H4	0.678	0.506	Acceptable
T & H5	0.675	0.515	Acceptable
T & H6	0.688	0.434	Acceptable
T & H7	0.677	0.501	Acceptable
T & H8	0.749	0.204	Acceptable
T & H9	0.757	0.161	Acceptable

7. CFA of Tourism & Hospitality

Table 5 and Table 6 show the Confirmatory Factor Analysis (CFA) of the six items of Hospitality Barriers. The result confirms that among nine items, six items are validated. The factor loading for first item "Insufficient communication skills for tourism staff" stands at 0.688. The second item "Local people attitude towards tourist" stands at 0.718. The third item "Lack of training to communicate Muslim foreign tourist" stands at 0.715. The fourth item "Unavailable sport facilities and recreational activities" stands at 0.695. The fifth item "Featuring Malay cultures and traditions rather than religious aspects" stands at 0.601. The Last item "Alcohol serving in hotels, restaurants and public places" stands at 0.593. All items were validated (Figure 10).

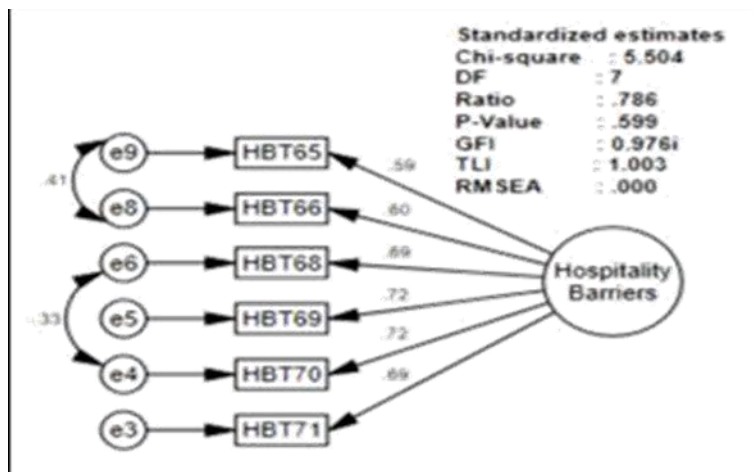

Figure 2: CFA of Tourism & Hospitality

Items	Variable	Estimate	S.E	C.R.	P
T & H1	Tourism & Hospitality	0.688	.077	13.778	0.000
T & H2	Tourism & Hospitality	0.718	.078	13.723	0.000
T & H3	Tourism & Hospitality	0.715	.071	14.663	0.000
T & H4	Tourism & Hospitality	0.695	.073	13.323	0.000
T & H5	Tourism & Hospitality	0.601	.064	12.540	0.000
T & H6	Tourism & Hospitality	0.593	.064	12.397	0.000

Table 6: Goodness of fit index of CFA Tourism & Hospitality

Index	Critical Ratio	Value
Chi-Square	00	5.504
DF	00	7
Ratio	< 2	.786
P-Value	> 0.05	0.599
GFI	> 0.9	0.997
TLI	> 0.9	1.003
RMSEA	< 0.08	0.000

Table 6 shows the Goodness of the Fit indexes of CFA Tourism and Hospitality. The ratio is less than 2 and the value .786 shows that the model is fit. The P-value with the ratio more than 0.05 and at the value 0.599, GFI being more than 0.9 at the value of 0.997, TLI with ratio more than 0.9 and value of 1.003, and finally RMSEA's critical ratio less than 0.08 and the value of 0.000 confirm this model to be significant and fit.

8. RECOMMENDATIONS AND CONCLUSION

The findings reveal that in terms of Islamic hospitality management in tourism, Muslim tourists expect all types of facilities those are related to Islamic principles at the tourism destination. For example, all the Muslim tourists prefer to have halal food at tourism sites, segregated halal kitchen and restaurants along with segregated swimming pools for men and women in the hotel and segregated areas for women at beaches. Most of the Muslim tourists recommended to have high quality restaurants located to the sea beach, mountains and natural settings, reasonable prices for hotels and others affordable facilities. Muslim tourists demand to have the unspoiled and good condition of the weather at the tourism destinations.

In 2009 an excellent pace was undertaken by the Tourism Malaysia and it established Islamic Tourism Centre (ITC) for increasing the prosperity in the market of Islamic approaches tourism and hospitality industry. On the other hand, after the tragedy of 11 September, 2001 Middle East Tourists keep coming to Malaysia for spending their leisure period. Consequently, they are demanding to get shariah complaint hotel and “they are also looking for the hospitality” (Samori & Rahman, p.98, 2013) which is directed according to Islamic approaches. In order to attract the tourists specially the Muslim tourists Malaysia is required to be famous in terms of tourism and hospitality industry by following Islamic approaches. Another benefit of following Islamic approaches towards tourism and hospitality industry is to increase brotherhood among Muslim countries. Din cites, “the spiritual goal [of travel] is to reinforce one’s submission to the ways of God; the social goal which follows is to encourage and strengthen the bond of silluturruhim (Muslim fraternity) among the ummah (Muslim community)” (p. 552, 1989).

In addition, Malaysian government should give more priority to establish tourism and hospitality industry based Islamic approaches. The government can follow some Islamic countries such as UAE and Balkan as its role model since UAE and Balkan have accentuated Islamic hospitality in their tourism industries (Samori, & Rahman, 2013). Nevertheless it can be noted that Muslim tourists specially tourists from Middle East and UAE are enriched with vast wealth and possess tendency to travel throughout the Muslim worlds. Beside this they “have higher purchasing power and this will benefit the countries they visit and offer Muslim-friendly facilities” (Samori & Rahman, p.98, 2013). Since for their travelling destination their first choice is Malaysia so it is the lucky chance for Malaysia to earn vast amount of revenue from this tourism and hospitality industry. So to welcome Muslim tourists proper Islamic hospitality approaches should be established and applied in everywhere such as market, hotel, resort, tourist spot, and road and so on.

REFERENCES

- Aasker, D.A., Kumar, V., & Day, G.S. (2001). *Marketing Research*. 7th. Ed., John Wiley and Sons. New York.
- Ala al-Hamarneh, (2011). *The emerging Islamic Tourism Global market: Rethinking the concepts, challenging the practices*.
- Amran Hamzah and Hampton, M. P. (2011). *Tourism development and change in small islands: lessons from Perhentian Kecil, Malaysia*. Centre for Innovative Planning and Development
- Bhuiyan, M. A. H., Siwar, C., & Shaharuddin Mohamad Ismail, S. M. (2013). Tourism Development in Malaysia from the Perspective of Development Plans. *Asian Social Science*, 9(9), 11-12.
- Byrne, B. M. (2010). *Structural Equation Modelling with AMOS: Basic Concepts, Applications and Programming*. New York: Taylor and Francis Group, LLC.
- Din, K. H. (1989). *Islam and tourism: Patterns, issues, and options*. *Annals of Tourism Research*, 16(4), 542-563.
- Farzel, L. (1997). *Investigating the Structure and Purpose of Fees in Franchise Agreements*, PhD Thesis University of Southern Queensland Toowoomba.
- Henderson, J. C. (2010). *Sharia-Compliant Hotels*. *Tourism and Hospitality Research*, 10(3), 246-254.
- High-level Intergovernmental Meeting on Sustainable Tourism Development (2005). *Major Issues in Tourism Development in The Asian and Pacific Region (Item 5 of the provisional agenda)* Note by the secretariat. Economic and Social Commission for Asia and the Pacific. *United Nations Economic and Social Council*. General E/ESCAP/ STD/2, 15 November, 2005. Original: English.
- Kandampully, J. (2007). *Services Management*. Upper Saddle River, N.J.: Pearson Prentice Hall.
- Kinney, T.C., & Taylor, J.R. (1996). *Marketing Research: An Applied Approach*, 5thEd., McGraw Hill.
- Liu, A. (2006). Tourism in rural areas: Kedah Malaysia. *Tourism management*, 27(5), 878–889.

- Malhotra, N.K. (1999). *Marketing Reserach, AnAppplied Orientation*. New Jersey: Prentice Hall, Upper Saddle River.
- Malhotra, N.K. (2004). *Marketing Reserach, An Appplied Orientation*, 4th. Edition, New Jersey: Pearson Education, Inc. Ministry of Tourism, Malaysia, 2012.
- Monograph 11 (2011). Faculty of Built Environment Universiti Teknologi Malaysia University of Kent, United Kingdom ISBN : 978-967-99997-9-2.
- Sekaran, U. (2003). *Research methods for business. A skill-building approach*. (4th ed). Queensland: Wiley.
- Samori, Z. & Rahman, F. A., (2013). Establishing shariah compliant hotels in Malaysia: Identifying opportunities, exploring challenges. *West East Journal of Social Sciences*, 2(2), 20-28.
- Shaida W., Rahman S. Ab, Awang k., Man Y. C., (2011). The Implementation of Shariah Compliance Concept Hotel: De Palma Hotel Ampang, Malaysia. 2011 *2nd International Conference on Humanities, Historical and Social Sciences* IPEDR 17 IACSIT Press, Singapore.
- Tourism Malaysia with the cooperation of Immigration Department Tourism Malaysia Official Corporate website, 2013
- World Tourism Organization (WTO), 2005. Tourism Highlights